

PHILIPS

Data handbook



Electronic
components
and materials

Components and materials

Part 6

1984

Synchronous motors and gearboxes

COMPONENTS AND MATERIALS

PART 6 1984

SYNCHRONOUS MOTORS AND GEARBOXES

	page
Survey of types	2
Introduction	3
Practical application	4
Quality	7
Additional information to motor specifications	8
Data sheets – unidirectional motors	10
– reversible motors	27
– gearboxes	85

DATA HANDBOOK SYSTEM

Our Data Handbook System is a comprehensive source of information on electronic components, sub-assemblies and materials; it is made up of four series of handbooks each comprising several parts.

ELECTRON TUBES	BLUE
SEMICONDUCTORS	RED
INTEGRATED CIRCUITS	PURPLE
COMPONENTS AND MATERIALS	GREEN

The several parts contain all pertinent data available at the time of publication, and each is revised and reissued periodically.

Where ratings or specifications differ from those published in the preceding edition they are pointed out by arrows. Where application information is given it is advisory and does not form part of the product specification.

If you need confirmation that the published data about any of our products are the latest available, please contact our representative. He is at your service and will be glad to answer your inquiries.

This information is furnished for guidance, and with no guarantee as to its accuracy or completeness; its publication conveys no licence under any patent or other right, nor does the publisher assume liability for any consequence of its use; specifications and availability of goods mentioned in it are subject to change without notice; it is not to be reproduced in any way, in whole or in part without the written consent of the publisher.

ELECTRON TUBES (BLUE SERIES)

The blue series of data handbooks is comprised of the following parts:

- T1** Tubes for r.f. heating
- T2a** Transmitting tubes for communications, glass types
- T2b** Transmitting tubes for communications, ceramic types
- T3** Klystrons, travelling-wave tubes, microwave diodes
- ET3** Special Quality tubes, miscellaneous devices (will not be reprinted)
- T4** Magnetrons
- T5** Cathode-ray tubes
Instrument tubes, monitor and display tubes, C.R. tubes for special applications
- T6** Geiger-Müller tubes
- T7** Gas-filled tubes
Segment indicator tubes, indicator tubes, dry reed contact units, thyratrons, industrial rectifying tubes, ignitrons, high-voltage rectifying tubes, associated accessories
- T8** Picture tubes and components
Colour TV picture tubes, black and white TV picture tubes, colour monitor tubes for data graphic display, monochrome monitor tubes for data graphic display, components for colour television, components for black and white television and monochrome data graphic display
- T9** Photo and electron multipliers
Photomultiplier tubes, phototubes, single channel electron multipliers, channel electron multiplier plates
- T10** Camera tubes and accessories, image intensifiers
- T11** Microwave semiconductors and components

SEMICONDUCTORS (RED SERIES)

The red series of data handbooks is comprised of the following parts:

- S1 Diodes**
Small-signal germanium diodes, small-signal silicon diodes, voltage regulator diodes (< 1,5 W), voltage reference diodes, tuner diodes, rectifier diodes
- S2 Power diodes, thyristors, triacs**
Rectifier diodes, voltage regulator diodes (> 1,5 W), rectifier stacks, thyristors, triacs
- S3 Small-signal transistors**
- S4a Low-frequency power transistors and hybrid modules**
- S4b High-voltage and switching power transistors**
- S5 Field-effect transistors**
- S6 R.F. power transistors and modules**
- S7 Microminiature semiconductors for hybrid circuits**
- S8 Devices for optoelectronics**
Photosensitive diodes and transistors, light-emitting diodes, displays, photocouplers, infrared sensitive devices, photoconductive devices.
- S9 Power MOS transistors**
- S10 Wideband transistors and wideband hybrid IC modules**

INTEGRATED CIRCUITS (PURPLE SERIES)

The purple series of data handbooks is comprised of the following parts:

- IC1** Bipolar ICs for radio and audio equipment
- IC2** Bipolar ICs for video equipment
- IC3** ICs for digital systems in radio, audio and video equipment
- IC4** Digital integrated circuits
CMOS HE4000B family
- IC5** Digital integrated circuits – ECL
ECL10 000 (GX family), ECL100 000 (HX family), dedicated designs
- IC6** Professional analogue integrated circuits
- IC7** Signetics bipolar memories
- IC8** Signetics analogue circuits
- IC9** Signetics TTL logic
- IC10** Signetics Integrated Fuse Logic (IFL)
- IC11** Microprocessors, microcomputers and peripheral circuitry

COMPONENTS AND MATERIALS (GREEN SERIES)

The green series of data handbooks is comprised of the following parts:

- C1 Assemblies for industrial use**
PLC modules, PC20 modules, HN1L FZ/30 series, NORbits 60-, 61-, 90-series, input devices, hybrid ICs
- C2 Television tuners, video modulators, surface acoustic wave filters**
- C3 Loudspeakers**
- C4 Ferroxcube potcores, square cores and cross cores**
- C5 Ferroxcube for power, audio/video and accelerators**
- C6 Synchronous motors and gearboxes**
- C7 Variable capacitors**
- C8 Variable mains transformers**
- C9 Piezoelectric quartz devices**
Quartz crystal units, temperature compensated crystal oscillators, compact integrated oscillators, quartz crystal cuts for temperature measurements
- C10 Connectors**
- C11 Non-linear resistors**
Voltage dependent resistors (VDR), light dependent resistors (LDR), negative temperature coefficient thermistors (NTC), positive temperature coefficient thermistors (PTC)
- C12 Variable resistors and test switches**
- C13 Fixed resistors**
- C14 Electrolytic and solid capacitors**
- C15 Film capacitors, ceramic capacitors**
- C16 Permanent magnet materials**
- C17 Stepping motors and electronics**
- C18 D.C. motors**
- C19 Piezoelectric ceramics**

PREFACE

New materials and manufacturing methods have enabled us to introduce motors to our range that have considerably improved characteristics and are at the same time less expensive. Some replace types that are widely used by many customers and, for this reason, are identical in fit and function to those they replace but with advantages in characteristics and price.

Notes

All mechanical drawings are in accordance with the European (third angle) projection.

Dimensions are given in mm.

Forces are given in newtons (N); $1 \text{ N} = 100 \text{ g} = 3,53 \text{ ounce (oz)}$.

Torques are given in milli-newton-metres (mNm); $1 \text{ mNm} = 10 \text{ gcm} = 0,139 \text{ ounce inch}$.

Performance curves are derived from measurements made on typical motors.

The sense of rotation, clockwise (cw) or counterclockwise (ccw), is as viewed from the spindle end of the motor.

When ordering, please use the catalogue number.

For full details on stepping motors, direct current motors and accessories, see Data Handbook C6.

SYNCHRONOUS MOTORS

SURVEY OF TYPES

torque mNm	size mm	speed rev/min	voltage V	catalogue number	page
Unidirectional synchronous motors					
0,08	φ 20 x 10	375	12 to 220	9904 110 09 . . . *	16
0,5	φ 35 x 10	250	110/220	9904 110 05 . . .	13
3,0	φ 51 x 12	250	110/220	9904 110 02 . . .	11
Reversible synchronous motors					
3,2/6**	φ 35 x 21	250/300**	24/48/110/117/220	9904 111 32 . . 4	57
4/7**	φ 35 x 21	250/300**	24/48/110/117/220	9904 111 32 . . 1	53
10	φ 51 x 25	250/300**	110	9904 111 31302*	41
20	φ 51 x 25	250/300**	24/48/110/220	9904 111 31 . . 4	49
20	φ 51 x 25	250/300**	24/48/110/220	9904 111 31 . . 1	45
33	φ 56 x 33,5	250/300**	24/48/110/220	9904 111 35 . . 4	69
33	φ 56 x 33,5	500	24/48/110/220	9904 111 36 . . 4*	73
20	φ 56 x 33,5	500	24	9904 111 36502	77
37,5	φ 44 x 76	250/300**	24/48/117/220	9904 111 06 . . . *	27
70	φ 68 x 58	250/300**	24/48/110/220	9904 111 27 . . .	31
70	φ 68 x 58	500	24/48/110/220	9904 111 28 . . . *	35
70	□ 69 x 41	250/300**	24/48/110/220	9904 111 33 . . 4	61
70	□ 69 x 41	500	24/48/110/220	9904 111 34 . . 4*	65
130	□ 69 x 100	500	220	9904 111 30112*	39
Hybrid synchronous motors					
180/220**	□ 57 x 51	60/72**	24/220	9904 116 23 . . 1	81

* Special purpose.

** At 50 Hz/60 Hz respectively.

INTRODUCTION

Synchronous motors are widely used in a variety of applications where accurate timing or programming is needed.

As all of our synchronous motors are of the permanent magnet type; instant start/stop characteristics are an inherent design feature.

Our range of synchronous motors comprises two major categories:

- Unidirectional motors
- Electrically reversible motors.

Unidirectional motors are mainly used in time switches operating in real time. In this type of application, the motor speed is reduced to 1 resolution in 24 hours via a gearwheel arrangement. Many years of continuous rotation are required, and, dependent on the time-switch function as well as the environmental conditions in which it is to operate, different torque outputs are required and various noise levels are acceptable. Time switches for industrial applications often have a large number of contacts which introduce relatively high peak loads when switching.

Time switches used in domestic environments do not have as many contacts and introduce relatively low peak loads when switching.

Our range of unidirectional motors covers both extremes. High torque versions for industrial applications and low torque, but noiseless versions, for domestic environments.

Reversible motors usually provide a time base for "interval timing" in a.c. servo systems which control industrial processes, central heating and air-conditioning systems, and medical equipments.

A typical application is the opening and closing of a valve. The instant start/stop characteristics of our synchronous motors and their accurate speed when running, make it possible to regulate an exact amount of liquid or gas passing through the valve.

As the torque and size requirements vary from the one application to the other, a complete range of reversible synchronous motors is available.

APPLICATION EXAMPLES

Industrial

Different types of clocks:

- control clocks
- master clock
- secondary clocks
- signal clocks
- rate change clocks
- switch clocks

Different types of time devices:

- delay relays
- time printers and stamps
- time checking devices
- time recorders
- time switches

Signal apparatus for air traffic control and waterway traffic control

Recording instruments

Electric stage control stands

Control equipment for the processing industry, and for heating and air-conditioning installations

Remote control units

Programme switches

Automatic vending machines

Consumer

Record players

Slide projectors

Domestic timers

Time switches for UV solaria.

PRACTICAL APPLICATION OF SYNCHRONOUS MOTORS

Starting characteristics

Except when used in direct drive systems, the output speed of a synchronous motor is usually reduced by means of a gearbox or gear train. Direct drive and reduction gear have different effects on motor starting characteristics.

a. Direct drive; load inertia plus friction.

When the load is directly and rigidly coupled to the motor spindle, the inertia of the load being driven has considerable effect on the starting characteristics. Unlike hysteresis synchronous motors, permanent magnet synchronous motors cannot run at sub-synchronous speeds. That is, the motor cannot run sub-synchronously (*slipping*) to accelerate the load inertia until it locks onto the mains frequency.

Where the available motor torque is little more than the torque needed to drive the load, there will not be enough remaining torque to accelerate up to synchronous speed. The rotor will tend to oscillate and given sufficient amplitude these oscillations may develop into a steady rotation. However it is impossible to predict how long this will take or whether rotation will be in the correct direction. If the motor starts in the wrong direction it may regain the correct direction after some milliseconds or, particularly if friction is low in the reverse direction, it may continue to run in the wrong direction. This happens more often with unidirectional shaded-pole motors than with reversible motors that have two stator coils and a phasing capacitor.

This phenomenon must be taken into account in determining the required torque and in selecting a suitable motor.

b. Indirect drive; gearboxes.

Although the fact that gearboxes reduce speed is well known, their effect on load inertia is often overlooked. The load inertia seen by the motor spindle is a function of the gear ratio, i.e.

$$J_{\text{motor}} = \frac{J_{\text{load}}}{n^2} .$$

Assuming a load inertia of 200 gcm² and a gear ratio of 40:1, the reflected inertia on the motor spindle is:

$$\frac{200}{40^2} = 0,125 \text{ gcm}^2 .$$

If a motor of sufficient torque is chosen it is clear that such an inertia will not cause starting difficulties. A further advantage of gearboxes is that backlash between gearwheels often allows the motor to start unloaded. The oscillation problems encountered with direct drive applications do not normally occur.

Flexible rotor motors

The above considerations apply to all permanent magnet motors in our range with the exception of the 9904 111 06 . . . series. In these the rotor is flexibly connected to the spindle by a leaf spring coupling that allows some free rotor motion on starting. When the coils are energized the rotor oscillates in the 'free' movement area until sufficient amplitude is developed to cause steady rotation. The duration of oscillation depends on the inertia of the load but is never more than milliseconds.

This unique flexible rotor design is able to accelerate much higher inertial loads than others of similar frame size.

Starting time, guidance figures:

Laboratory measurements have shown that under unfavourable conditions a unidirectional motor needs 250 ms to start while a reversible motor needs 80 ms. In properly designed applications the starting times are considerably shorter.

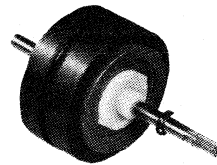

800703-12-01

Stall conditions

In some applications, mechanical 'end-stops', together with switches to reverse or switch-off the motor, are used to stop the motor after a given number of revolutions. If the motor is not switched-off or reversed on reaching the end-stops, the rotor will oscillate in attempting to continue rotation. This oscillation causes noise, which is usually unacceptable.

Where the noise is acceptable or is suppressed mechanically, temperature rise in the motor need be of no concern. All synchronous motors in our range, with the exception of the special purpose motors with a 50% duty cycle, can withstand stalling indefinitely.

Stopping characteristics

Because their powerful permanent magnets rotate close to the stator, permanent magnet motors generate a strong braking torque when the current is interrupted. Although the amount a rotor continues to rotate after interruption of the current is dependent on the kinetic energy stored in the load it will not normally be more than 20°.

Measuring motor torque

There are several ways of measuring the torque of a permanent magnet synchronous motor. In our laboratories we use instruments of very great accuracy. Such instruments are unsuited to production line use because of the time it takes to make measurements. It is better to use simpler devices that are regularly calibrated and adjusted. As the torque of permanent magnet synchronous motors can best be measured when started from no-load conditions, a torque-meter or pulley and spring arrangement offer an acceptable compromise.

Figure 2 shows a suitable arrangement in which a string of diameter d is wound around a pulley of diameter D and is attached to a coil spring with spring constant C . When started the motor continues to rotate until its developed torque matches the force exerted by the spring. If the displacement of a needle attached to the spring is then $\Delta\ell$, the motor torque is given by:

$$M = (1/2D + 1/2d) \times C \times \Delta\ell.$$

The scale can also be graduated to read off torque directly. It is important to keep the mass of the pulley as low as possible for accurate results.

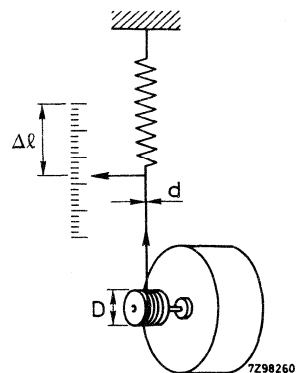

Fig. 2.

Mounting pulleys and pinions on a motor spindle

Our synchronous motors have an excellent torque-to-size ratio and very smooth running characteristics. We obtain this by using carefully produced stator parts, well balanced rotors and by maintaining close tolerances on the air gap between rotor and stator. In consequence they must be treated as delicate instruments.

Pinions and pulleys should be fitted with care and with well-matched tolerances between spindle and bore if they are press-fitted together. The spindle should be properly supported in line with the pulley or pinion bore during the press-fit operation.

If adhesives are used, careful attention should be paid to the dosage so that adhesive does not penetrate between spindle and bearing.

HYBRID SYNCHRONOUS MOTORS

Our range of synchronous motors has recently been extended by the addition of hybrid motors of a new patented design. These motors have a low spindle speed of 60 rev/min at 50 Hz or 72 rev/min at 60 Hz. They excel in rapid starting, stopping and reversing. The working principle is shown in Fig. 3. Although the drawing only shows one tooth per stator cup and one tooth per rotor disc there are in fact fifty to obtain the low spindle speed mentioned above.

The design differs from other hybrid synchronous motors in having the magnet in the stator package. This means that the flux paths also differ. The permanent magnet passes a flux from the one stator part to the other via the rotor. Depending on the initial rotor position (i.e. the position of the teeth), the flux through disc 1 will be greater than that through disc 2, or vice versa. However, the sum of the two fluxes will remain constant. The same holds for discs 3 and 4.

When a coil is excited, an electromagnetic flux flows from one stator cup through two rotor discs to the other cup of the same stator part. The permanent magnet acts as a large air gap so that the two stator parts are almost magnetically separate. The flux due to excitation of the coil adds to the permanent magnet flux in one disc and cup and subtracts from it in the other. The rotor moves to align the teeth of the disc with the teeth of the stator cup to reach the position of highest flux density. When operated from the mains the coils are excited alternately, causing polarity changes. A phasing capacitor connected in series with either coil gives the requisite phase shift to start and rotate in the appropriate direction.

This type of motor is eminently suited to applications requiring compactness and high torque. When a still lower speed is required only a minimum number of mechanical parts are needed. In many cases a single pinion and gear wheel or a toothed pulley and belt arrangement will suffice.

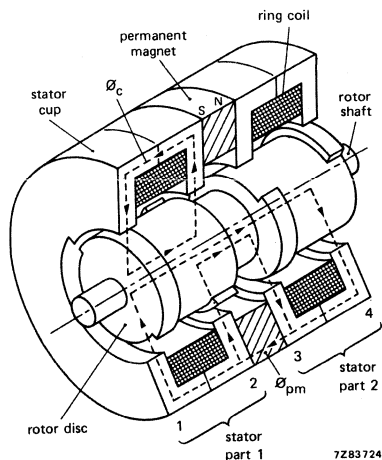

Fig. 3.

QUALITY

Quality is our constant aim, from the moment the idea for a motor design is born to the last day of operation. Quality control, therefore, is probably the most important aspect of the entire marketing activity.

To achieve the highest possible standard a procedure of many checks is carried out:

- during development, prior to Release for Development Sample production;
- during the pilot production, to optimize conditions for mass production;
- during series production, after Release for Production.

With this procedure quality assurance is realized.

DEVELOPMENT

The examination during development includes material inspection and verification of the development specification.

Quality checks on development samples include:

- visual inspection, including operational noise due to friction;
- dimensional checks on critical dimensions and spindle deviation;
- mechanical and electrical tests, e.g. on directional stability of rotation, torque, current;
- safety tests, both on insulation resistance and dielectric strength;
- climatic tests;
- life and endurance tests.

PILOT PRODUCTION

Once the product has passed this development stage, a pilot production should prove the reproducibility.

The mechanical tests are based on performance during operation. Special conditions can be simulated, also upon customer's demand. Besides, batch tests of packed motors are carried out (dropping and bounce tests) as well as vibration and shock tests on motors mounted on a frame.

The climatic tests include functional checks at -20°C unless otherwise specified, temperature cycle tests, -40 to $+85^{\circ}\text{C}$, (5 cycles, total 30 h), damp heat cycle tests (6 days) and dry heat storage tests at the maximum specified storage temperature (96 h).

The life tests are accelerated tests during 2000 h under extreme conditions of load and temperature and continuous tests under normal operating conditions.

SERIES PRODUCTION

Products which pass all these tests during the pilot production stage are released for factory production. Production lots are submitted to lot acceptance tests according to MIL-STD-105D procedure. Unless otherwise specified, inspection level I and an AQL of 1% for major defects are set as limit. During series production a process control carried out at various stages reduces the error initiation to a great extent.

QUALITY ASSURANCE

The combination of release tests and production tests reflects actual operation conditions and practical experience from the field assures that our synchronous motors render a fully satisfactory service for many years. The well-considered design and the stringent quality procedure account for the highest possible degree of reliability.

ADDITIONAL INFORMATION TO MOTOR SPECIFICATIONS

The values given in the data sheets apply at an ambient temperature of 22 ± 5 °C, an atmospheric pressure of 86 to 106 kPa and a relative humidity of 45 to 75% (free circulating air). Unless otherwise specified the values are typical, except those for minimum torque which are measured at minimum voltage and nominal phasing capacitance.

The curves in the performance graphs are at nominal voltage on arbitrary motors of the relevant types. Torque derating expressed in %/K applies above 22 °C and is given with respect to the torque at 22 °C. At lower temperatures in the permissible temperature range there will be some delay in the motor reaching synchronous speed.

The temperature rise of a special purpose synchronous motor is given at 50% duty cycle. These types are very suitable for applications which require high torque and intermittent use. To achieve the high torque characteristic, the power input is nearly twice as high as that of a standard version of the same volume. Consequently, the temperature rise of a special purpose synchronous motor does not allow for continuous operation without considering the ambient temperature.

Figures 1, 2 and 3 show the temperature behaviour of a motor for intermittent operation and are helpful in determining the permissible ambient temperature in which the special purpose synchronous motor can be used.

Figure 1 shows the temperature rise of the (special purpose) synchronous motor in continuous operation for 90 minutes, and the cooling characteristic after switching off. The temperature rise is measured at maximum voltage and maximum phasing capacitance.

Figure 2 shows 5 temperature cycles of 30 minutes in which the motor is switched-on for 20 minutes and switched-off for 10 minutes. In the first cycle the temperature is raised by about 50 K and falls by about 15 K in the second cycle, 24 K and 18 K respectively. After several cycles a maximum temperature rise of 60 K is reached. For a motor with a maximum permissible temperature of 110 °C, the ambient temperature may not exceed 50 °C in this case.

The maximum ambient temperature differs for different duty cycles. The maximum ambient temperature as a function of the cycle time and the duty cycle is given in Fig. 3. The upper limit is 70 °C (intermittent operation), the lower limit is 40 °C (continuous operation is permitted).

7Z83743A

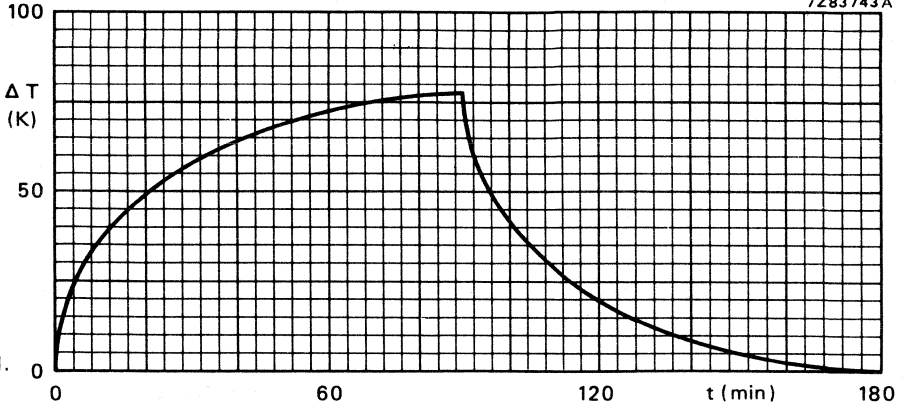

Fig. 1.

7Z83742A

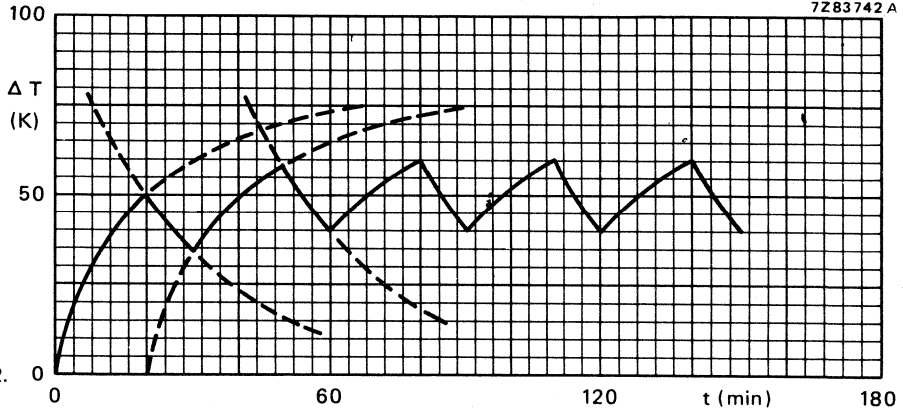

Fig. 2.

7Z83744

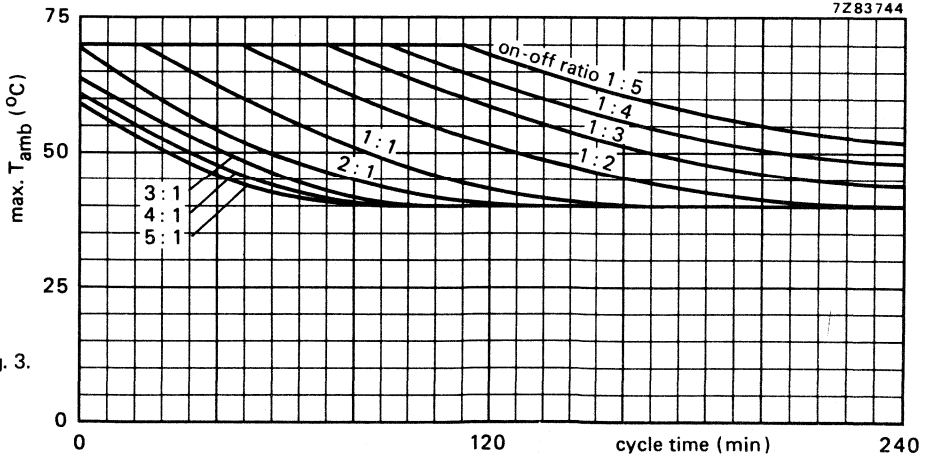
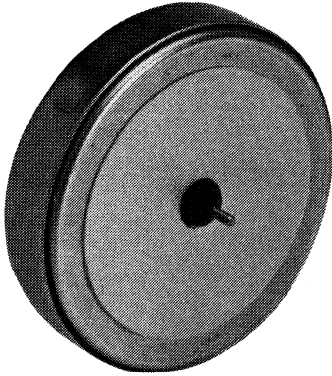

Fig. 3.

UNIDIRECTIONAL SYNCHRONOUS MOTORS

830711-01-14



9904 110 02 . . .
general purpose

830711-01-15

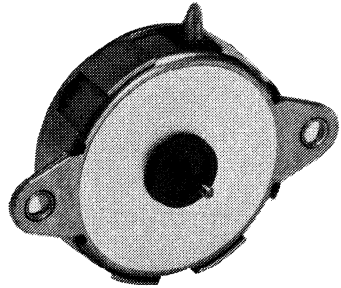

9904 110 05 . . .
general purpose

830711-01-13

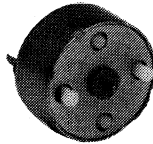

9904 110 09 . . .
special purpose

UNIDIRECTIONAL SYNCHRONOUS MOTORS

general purpose

QUICK REFERENCE DATA

Nominal voltage	220 V	110 V
Frequency	50 Hz	50 Hz
Speed	250 rev/min	250 rev/min
Input power	1,6 W	1,6 W
Torque	3 mNm	3 mNm

APPLICATION

These motors have been designed to provide an accurate and reliable timebase for a variety of industrial applications. They are ideally suitable for use in delay relays, time switches, time printers, signal clocks and master clocks.

TECHNICAL DATA

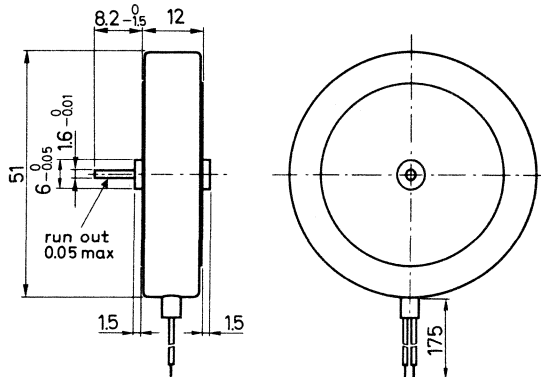

Fig. 1a.

Note: Motors with different voltage ratings, or provided with a pinion (see Fig. 1b), are available on request only in minimum order quantities, and involve longer delivery times.

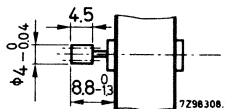

Fig. 1b Version with pinion:
 number of teeth = 10;
 module = 0,3;
 addendum modification = + 0,2.

Mounting

A mounting bracket 9904 131 01001 is described at the back of this book.

clockwise rotation counter-clockwise rotation	catalogue number		
	9904 110 02101 9904 110 02111	9904 110 02301 9904 110 02311	
Nominal voltage	220	110	V
Frequency	50	50	Hz
Speed	250	250	rev/min
Current	7,5	17	mA
Input power		1,6	W
Starting torque		2,5	mNm
Working torque		3	mNm
Torque derating		0,6	%/K
Temperature rise of the motor		30	K
Ambient temperature range		-20 to + 70	°C
Permissible voltage fluctuations		-15 to + 10	%
Insulation according to CEE10		class 2	
Insulation test voltage		2500	V
Bearings		polyamide slide	
Maximum radial force		0,9	N
Maximum axial force		0,5	N
Maximum inertial load		0,15	gcm ²
Housing		zinc plated	
Mass		90	g

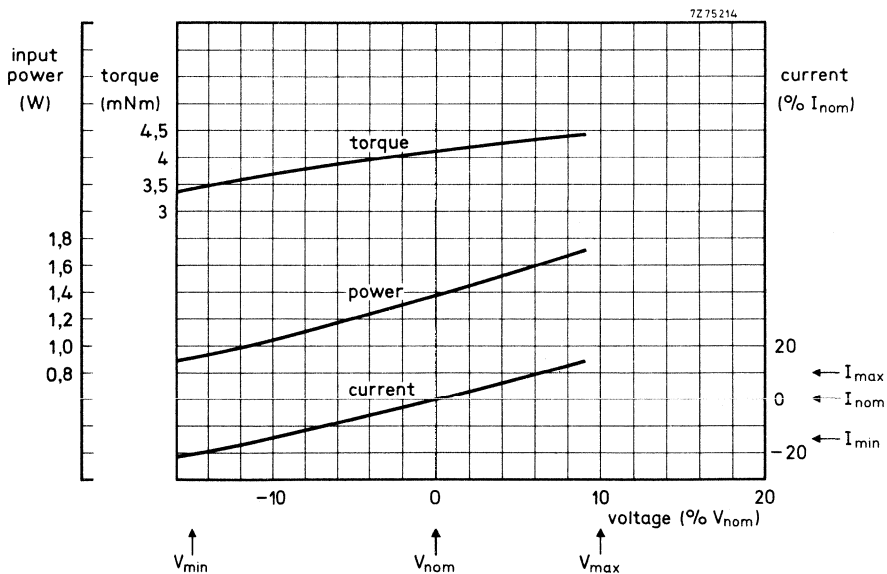

Fig. 2 Typical curves.

UNIDIRECTIONAL SYNCHRONOUS MOTORS

general purpose

QUICK REFERENCE DATA

Nominal voltage	220 V	110 V
Frequency	50 Hz	50 Hz
Speed	250 rev/min	250 rev/min
Input power	1,8 W	0,5 W
Torque	0,5 mNm	0,5 mNm

APPLICATION

These motors have been designed for optimum performance in equipment where the available space is limited and a high torque is required. The 220 V version operates via a series resistor to keep the dimensions of the motor as small as possible. The motors find their application in a variety of small timing devices.

TECHNICAL DATA

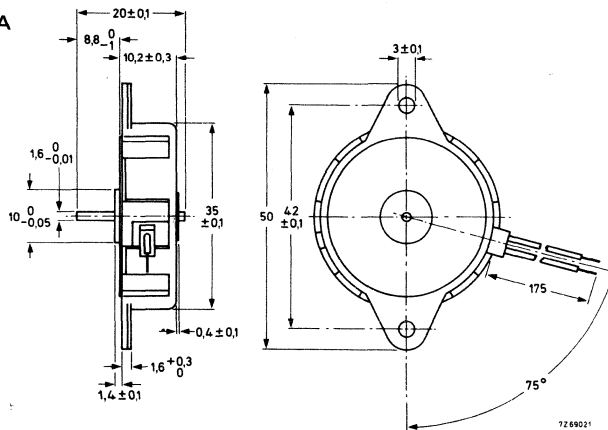

Fig. 1a Plain version.

Note: Motors with different voltage ratings, or provided with a pinion (see Fig. 1b), are available on request only in minimum order quantities, and involve longer delivery times.

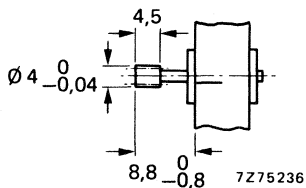

Fig. 1b Version with pinion:
number of teeth = 10;
module = 0,3;
addendum modification = + 0,2.

	catalogue number		
	9904 110 05102*	9904 110 05301	
clockwise rotation	9904 110 05112*	9904 110 05311	
counter-clockwise rotation			
Nominal voltage	220	110	V
Frequency	50	50	Hz
Speed	250	250	rev/min
Current	8	5	mA
Input power	1,8	0,5	W
Starting torque		0,5	mNm
Working torque		0,5	mNm
Torque derating		0,6	%/K
Temperature rise of the motor		20	K
Ambient temperature range		-20 to + 70	°C
Permissible voltage fluctuations		-15 to + 10	%
Insulation according to CEE10		class 1	
Insulation test voltage		2500	V
Bearings		polyamide slide	
Maximum radial force		0,3	N
Maximum axial force		0,1	N
Maximum inertial load		0,05	gcm ²
Housing		zinc plated	
Mass		40	g

* This motor has to be used with a series resistor (20 kΩ, 2 W), which can be supplied on request.

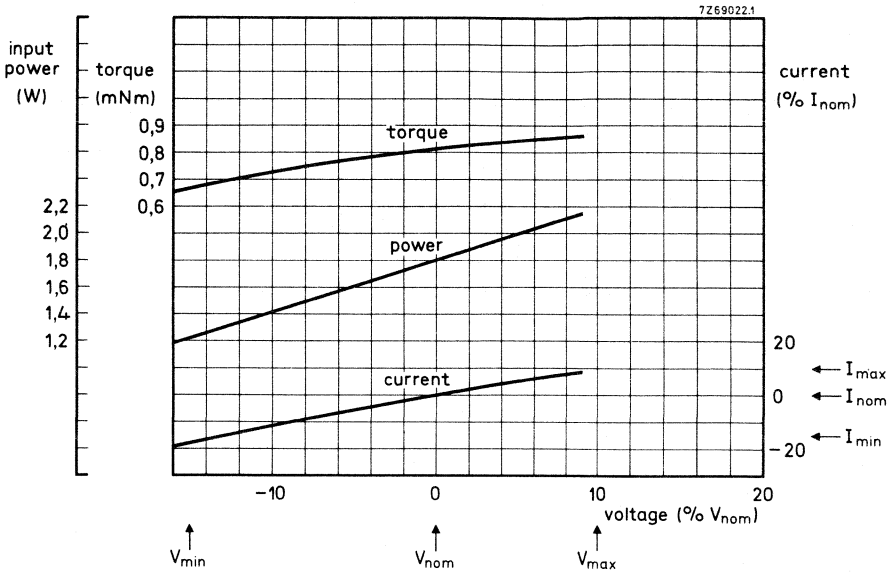

Fig. 2a Typical curves of 220 V motors.

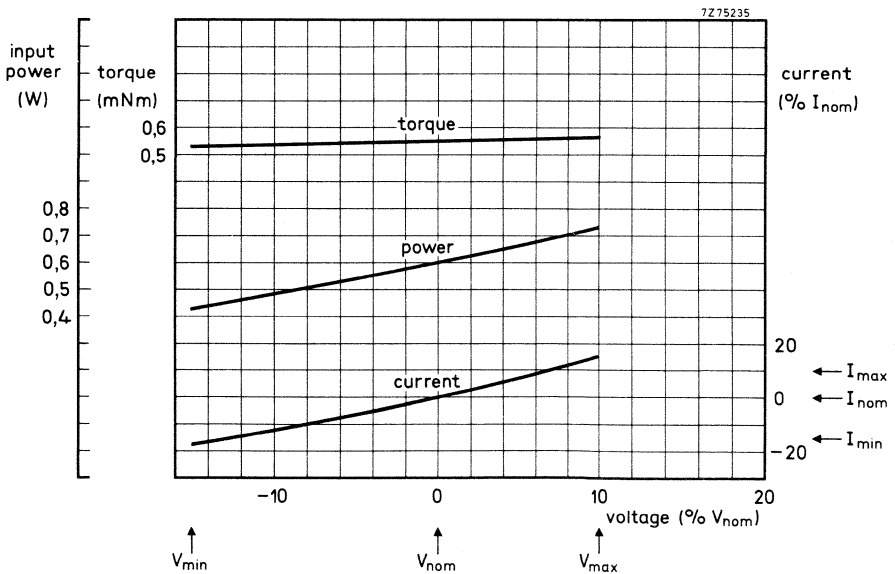

Fig. 2b Typical curves of 110 V motors.

UNIDIRECTIONAL SYNCHRONOUS MOTORS

special purpose

QUICK REFERENCE DATA

Nominal voltage	12 V, 50 Hz	24 V, 50 Hz	24 V, 50 Hz (silent version)	110 V/220 V, 50 Hz
Speed	375 rev/min	375 rev/min	375 rev/min	375 rev/min
Input power	0,2 W	0,2 W	0,12 W	0,75 W/1,5 W
Torque	0,08 mNm	0,08 mNm	0,03 mNm	0,08 mNm

APPLICATION

These miniature timing motors are designed to drive small clock mechanisms specifically where low power consumption (thus low temperature rise) is required and where small dimensions are preferred.

Versions are available for 12 V, 24 V, or 110 V/220 V operation at 50 Hz. The low power consumption of the 12 V and 24 V types allows battery operation (via d.c./a.c. converter). For applications which normally use hysteresis motors, with their unfavourable volume-to-output ratio, a much better proposition is the silent 24 V version. The 12 V and 24 V versions can operate from the mains but, to obtain optimum results, it is preferable to use the 110 V/220 V version (in each case the appropriate resistor or capacitor is required in series with the motor coil).

Typical applications are:

- electronic car clocks;
- rate change clocks in electricity meters;
- central heating control clocks;
- miniature time switches;
- miniature elapsed-time indicators.

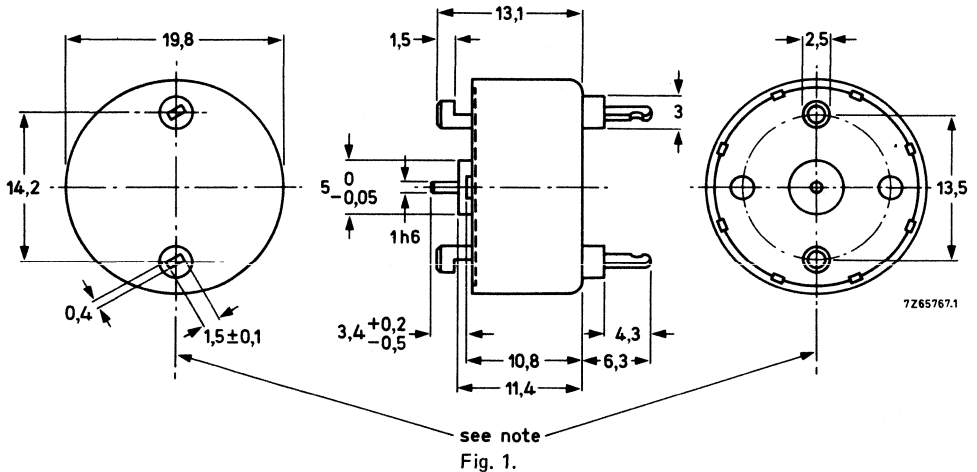

Note: The angle between the axial plane through the centres of the mounting pins and the axial plane through the centres of the solder tags is maximum 2° 30'.

Mounting

Two plastic twist-lock mounting pins are provided, but can be cut off if desired. Maximum thickness of mounting plate is 0,8 mm.

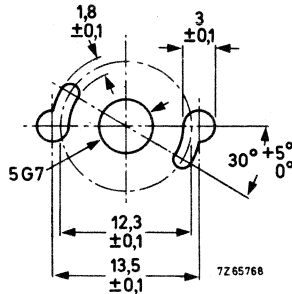

Fig. 2.

12 V version*

	catalogue number		
	9904 110 09701	9904 110 09711	
clockwise rotation			
counter-clockwise rotation			
Nominal voltage	12	6	V
Frequency	50	50	Hz
Speed	375	375	rev/min
Current	18	9	mA
Input power	0,2	0,05	W
Working torque	0,08	0,02	mNm
Torque derating	-0,6	-0,6	%/K
Temperature rise of the motor	16	4	K
Ambient temperature range			
operating	-30 to + 85	-10 to + 85	°C
storage	-40 to + 100	-40 to + 100	°C
Permissible voltage fluctuations	-15 to + 10	0 to + 110	%
Insulation according to CEE10		class 3	
Insulation test voltage		500	V
Bearings		sintered bronze slide	
Maximum radial force		0,05	N
Maximum axial force		0,05	N
Maximum inertial load		0,002	gcm ²
Housing		steel, zinc plated	
Mass		14	g

For typical curves, see Fig. 3a.

* This version can also be used for operation at 110 V/220 V, 50 Hz provided the appropriate resistor or capacitor is connected in series with the motor coil see "Additional information". The data for 6 V operation are empiric, they are not guaranteed and are for guidance only.

24 V version *

	catalogue number		
	9904 110 09601	9904 110 09611	
clockwise rotation			
counter-clockwise rotation			
Nominal voltage	24	12	V
Frequency	50	50	Hz
Speed	375	375	rev/min
Current	9	4,5	mA
Input power	0,2	0,05	W
Working torque	0,08	0,02	mNm
Torque derating	-0,6	-0,6	%/K
Temperature rise of the motor	16	4	K
Ambient temperature range			
operating	-30 to + 85	-10 to + 85	°C
storage	-40 to + 100	-40 to + 100	°C
Permissible voltage fluctuations	-15 to + 10	0 to + 110	%
Insulation according to CEE10	class 3		
Insulation test voltage	500		V
Bearings	sintered bronze slide		
Maximum radial force	0,05		N
Maximum axial force	0,05		N
Maximum inertial load	0,002		gcm ²
Housing	steel, zinc plated		
Mass	14		g

For typical curves, see Fig. 3b.

* This version can also be used for operation at 110 V/220 V, 50 Hz provided the appropriate resistor or capacitor is connected in series with the motor coil, see "Additional information". The data for 12 V operation are empiric; they are not guaranteed and are for guidance only.

24 V Silent version *

	catalogue number	
	clockwise rotation	counter-clockwise rotation
	9904 110 09501	9904 110 09511
Nominal voltage	24	V
Frequency	50	Hz
Speed	375	rev/min
Current	5,3	mA
Input power	0,12	W
Working torque	0,03	mNm
Torque derating	-0,6	%/K
Temperature rise of the motor	10	°C
Ambient temperature range		
operating	-10 to + 85	°C
storage	-40 to + 100	°C
Permissible voltage fluctuations	-15 to + 10	%
Insulation according to CEE10	class 3	
Insulation test voltage	500	V
Bearings	sintered bronze slide	
Maximum radial force	0,05	N
Maximum axial force	0,05	N
Maximum inertial load	0,002	gcm ²
Housing	steel, zinc plated	
Mass	14	g
Noise level**	30 (typical value)	dB—A scale

For typical curves, see Fig. 3c.

* This version can also be used for operation at 110 V/220 V, 50 Hz provided that the appropriate resistor or capacitor is connected in series with the motor coil, see "Additional information".

** Measured with Bruel and Kjaer sonometer, type 2203; microphone at 40 mm from the motor, which is mounted on a gearbox.

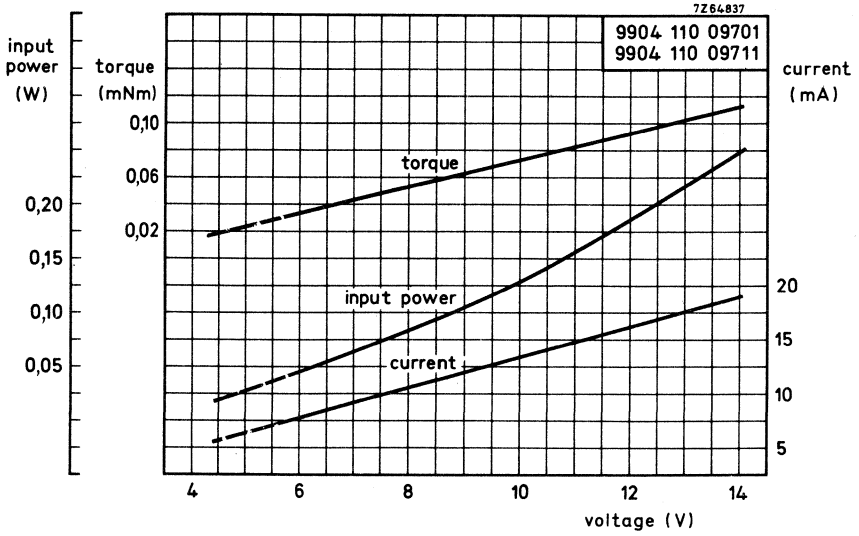

Fig. 3a Typical curves of 12 V motors.

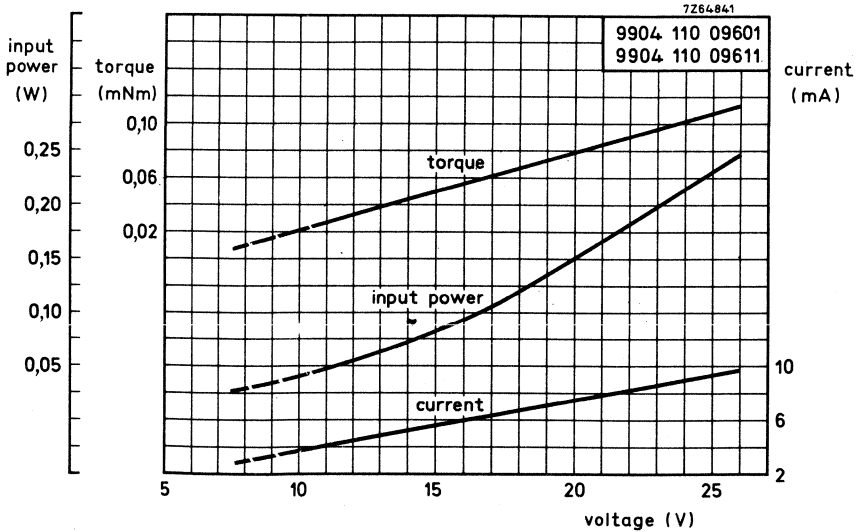

Fig. 3b Typical curves of 24 V motors.

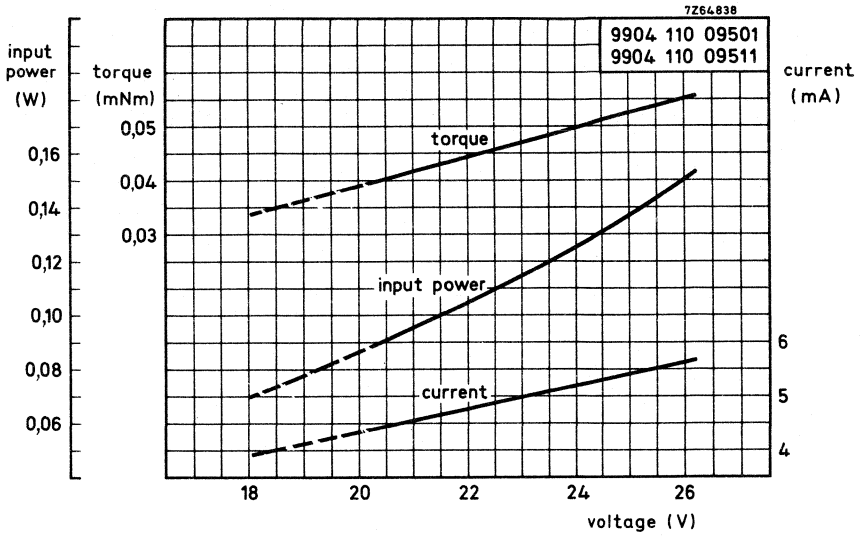

Fig. 3c Typical curves of 24 V silent version motors.

Versions for mains operation

	catalogue number				
	9904 110 09101 9904 110 09111				
clockwise rotation					
counter-clockwise rotation					
Mains voltage*	110		220		V
	low-torque mode	high-torque mode	low-torque mode	high-torque mode	
Required series resistor, $\pm 5\%$	22	10	47	24	k Ω
maximum power dissipation	0,5	0,7	1,1	1,6	W
Frequency	50	50	50	50	Hz
Speed	375	375	375	375	rev/min
Current	4,5	8	4	7	mA
Input power	0,47	0,75	0,94	1,5	W
Working torque	0,02	0,08	0,02	0,08	mNm
Torque derating	-0,6	-0,6	-0,6	-0,6	%/K
Temperature rise of the motor	6	21	6	21	K
Ambient temperature range					
operating	-15 to + 85				$^{\circ}\text{C}$
storage	-40 to + 100				$^{\circ}\text{C}$
Permissible voltage fluctuations	-15 to + 10				%
Insulation according to CEE10	class 3				
Insulation test voltage	500				V
Bearings	sintered bronze slide				
Maximum radial force	0,05				N
Maximum axial force	0,05				N
Maximum inertial load	0,002				gcm ²
Housing	steel, zinc plated				
Mass	14				g

For typical curves, see Fig. 4.

For use of a series capacitor instead of a series, see "Additional information".

* If used in low torque mode, the motor noise is reduced at minimum.

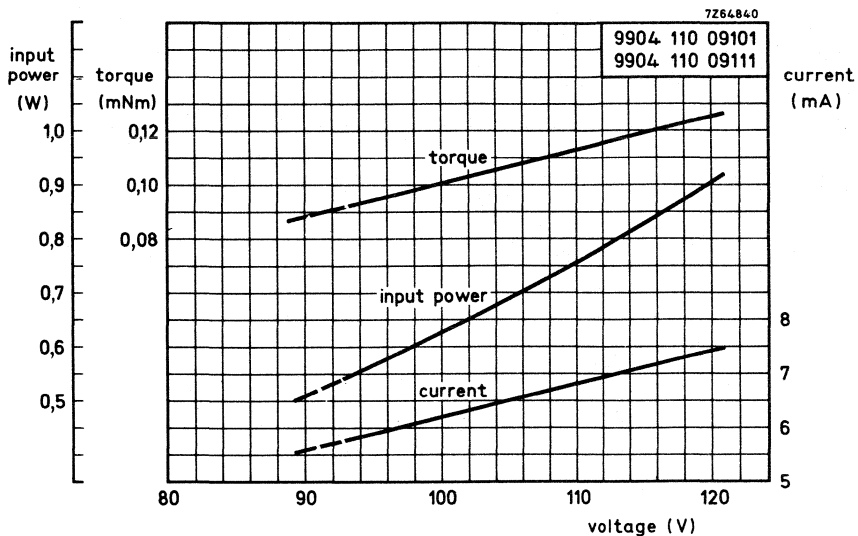

Fig. 4a Typical curves of motors used with a series resistor of 10 kΩ.

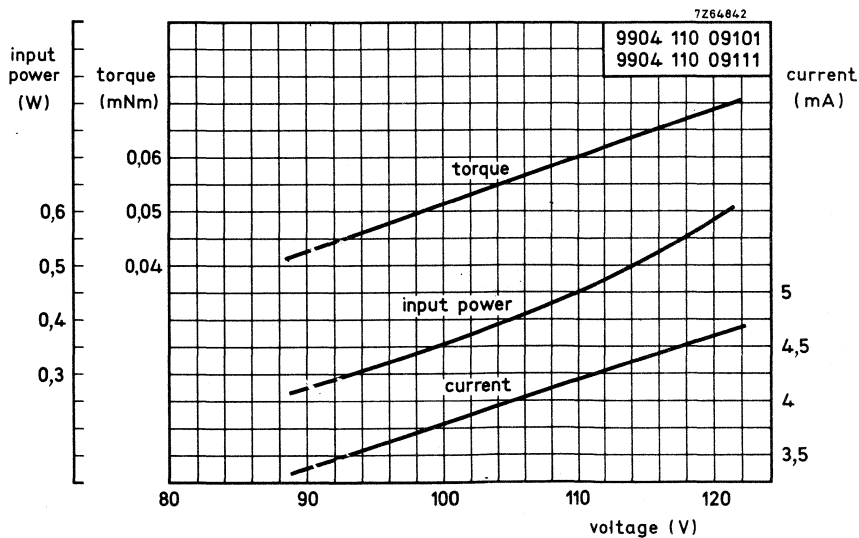

Fig. 4b Typical curves of motors used with a series resistor of 22 kΩ.

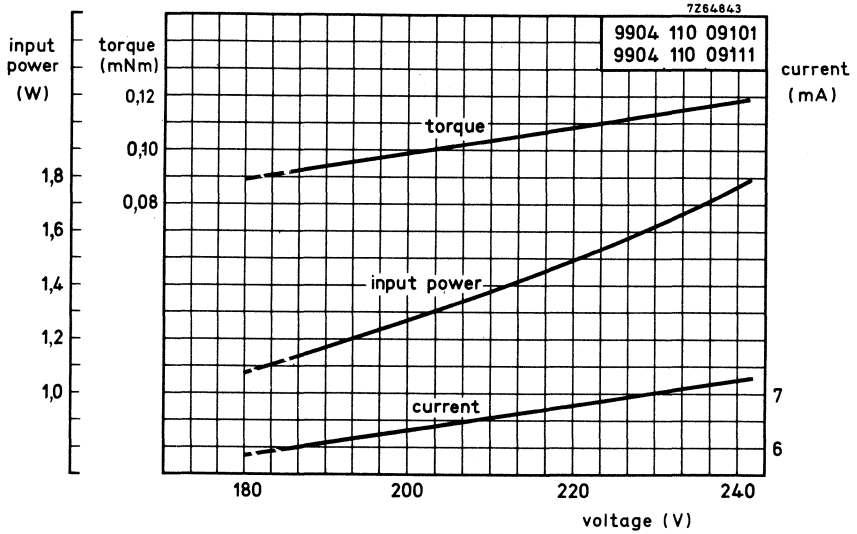

Fig. 4c Typical curves of motors used with a series resistor of 24 kΩ.

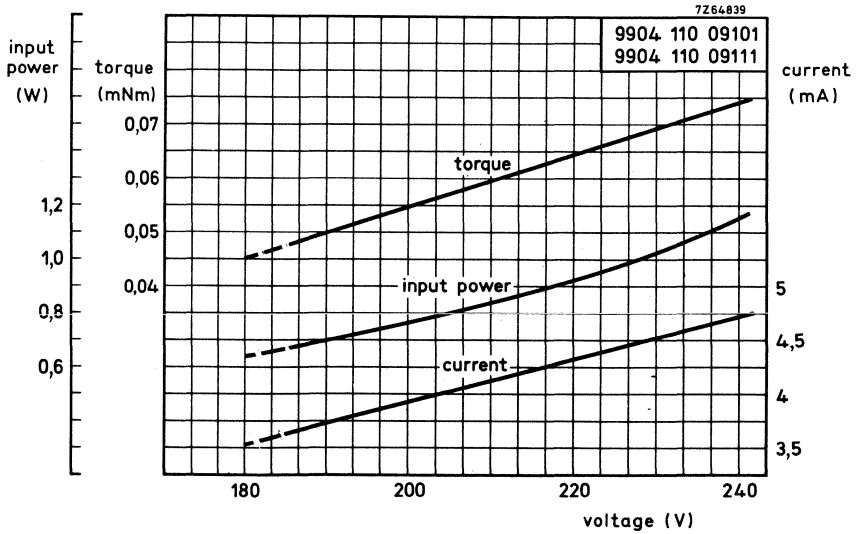

Fig. 4d Typical curves of motors used with a series resistor of 47 kΩ.

ADDITIONAL INFORMATION

For mains operation a resistor or capacitor must be connected in series with the motor coil. This may affect some of the specified values for motors not specified for mains operation.

Recommended resistors and capacitors at 110 V a.c.

motor type	R ± 5%		C ± 10%, 125 V (a.c.)	
	low torque mode	high torque mode	low torque mode	high torque mode
9904 110 09601 09611	18 kΩ (0,7 W)	10 kΩ (1,2 W)	0,15 μF	0,22 μF
9904 110 09701	10 kΩ (1,4 W)	5,6 kΩ (2,2 W)	0,33 μF	0,47 μF
9904 110 09101 09111	22 kΩ (0,5 W)	10 kΩ (0,7 W)	0,12 μF	0,18 μF
9904 110 09511 09511	12 kΩ (1 W)		0,18 μF	

Recommended resistors and capacitors at 220 V a.c.

motor type	R ± 5%		C ± 10%, 250 V (a.c.)	
	low torque mode	high torque mode	low torque mode	high torque mode
9904 110 09601 09611	39 kΩ (1,4 W)	24 kΩ (2,0 W)	0,068 μF	0,12 μF
9904 110 09701 09711	20 kΩ (2,9 W)	12 kΩ (4 W)	0,15 μF	0,22 μF
9904 110 09101 09111	47 kΩ (1,1 W)	24 kΩ (1,6 W)	0,056 μF	0,082 μF
9904 110 09501 09511	27 kΩ (2 W)		0,082 μF	

REVERSIBLE SYNCHRONOUS MOTORS

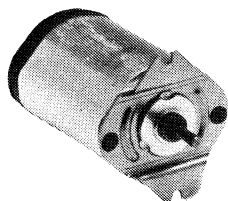

830711-01-02

9904 111 06 ...

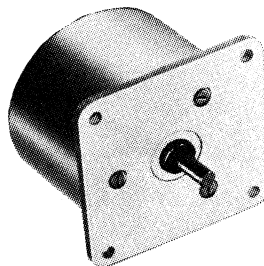

761224-10-06

9904 111 27 ...; 9904 111 28 ...

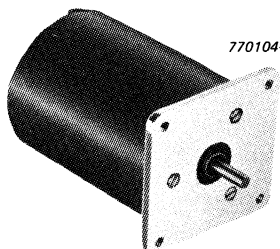

770104-14-01

9904 111 30 ...

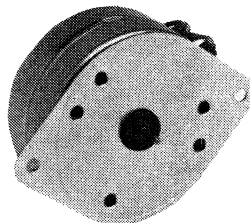

830711-01-22

9904 111 31 ...

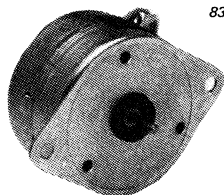

830711-01-16

9904 111 32 ...

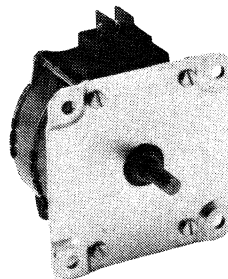

830711-01-03

9904 111 33 ... 4; 9904 111 34 ... 4

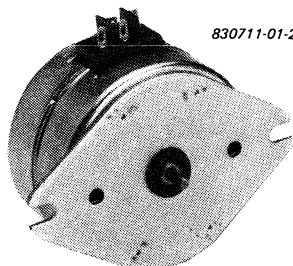

830711-01-23

9904 111 35 ...; 9904 111 36 ...

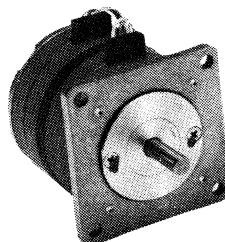

830711-01-04

9904 116 23 ... 1

REVERSIBLE SYNCHRONOUS MOTORS

special purpose

QUICK REFERENCE DATA

Nominal voltage	220 V	117 V	110 V	48 V	24 V
Frequency	50 Hz	60 Hz	50 Hz	50 Hz	50 Hz
Speed	250 rev/min	300 rev/min	250 rev/min	250 rev/min	250 rev/min
Input power	5 W	6 W	5 W	5 W	5 W
Torque	37,5 mNm	37,5 mNm	37,5 mNm	37,5 mNm	37,5 mNm

APPLICATION

These motors are especially suitable in applications which require high torque and the capability to start relatively high inertia loads, e.g. medical instrumentation. They have a unique rotor design (see "Principles-starting characteristics") and a slender configuration.

Apart from their widespread use in medical equipment, these motors are to be found in an increasing variety of applications, for example, traffic control equipment, textile machines, and radar displays.

TECHNICAL DATA

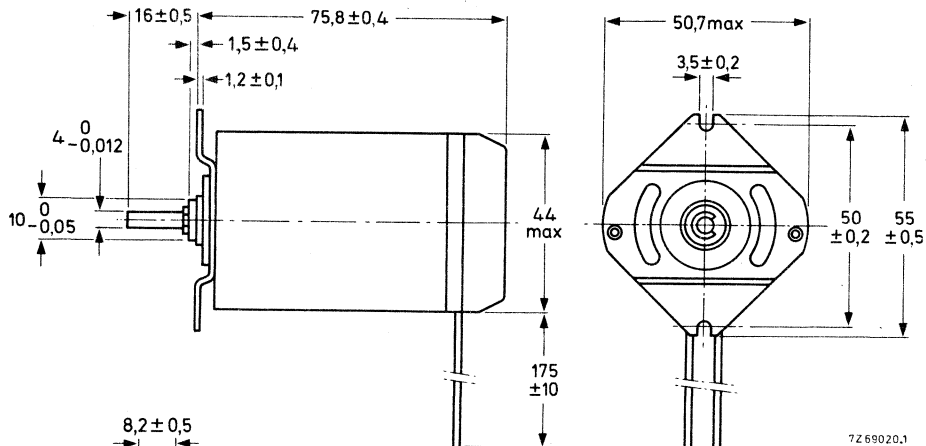

Fig. 1a Version with ϕ 4 mm spindle.

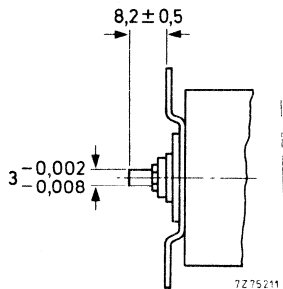

Fig. 1b Version with ϕ 3 mm spindle, for combination with gearbox series 9912 200

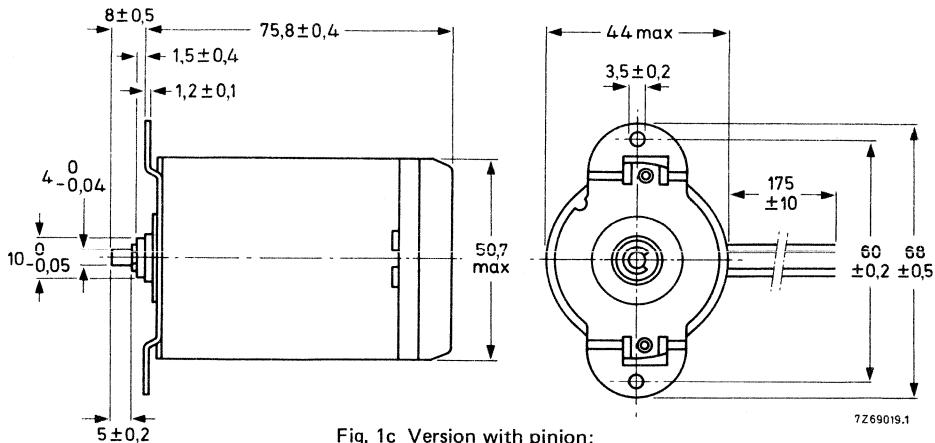

Fig. 1c Version with pinion:
 number of teeth = 10;
 module = 0,3;
 addendum modification = + 0,2.

	catalogue number 9904 111 06 . . .					
	101	201	301	401	501	
versions with spindle ϕ 3 mm	101	201	301	401	501	
versions with spindle ϕ 4 mm	111	211	311	411	511	
versions with pinion	131		331	431	531	
Nominal voltage	220	117	110	48	24	V
Frequency	50	60	50	50	50	Hz
Speed	250	300	250	250	250	rev/min
Current	27	60	50	110	200	mA
Input power	5	6	5	5	5	W
Starting torque	30	30	30	25	30	mNm
Working torque	37,5	37,5	37,5	35	37,5	mNm
Torque derating	0,4	0,4	0,4	0,4	0,4	%/K
Temperature rise of the motor	35	45	35	35	35	K
Ambient temperature range	-20 to +70					$^{\circ}$ C
Permissible voltage fluctuations	-10 to +10					%
Insulation according to CEE10	class 2					
Insulation test voltage	2500					V
Bearings	sintered iron slide					
Maximum radial force	15					N
Maximum axial force	1,5					N
Housing	aluminium					
Mass	300					g
Required phasing capacitor	0,18	0,68	0,68	3,5	14	μ F
permissible a.c. voltage	330	250	250	160	160	V

Connections

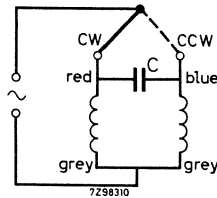

Fig. 2 Connections of the phasing capacitor.

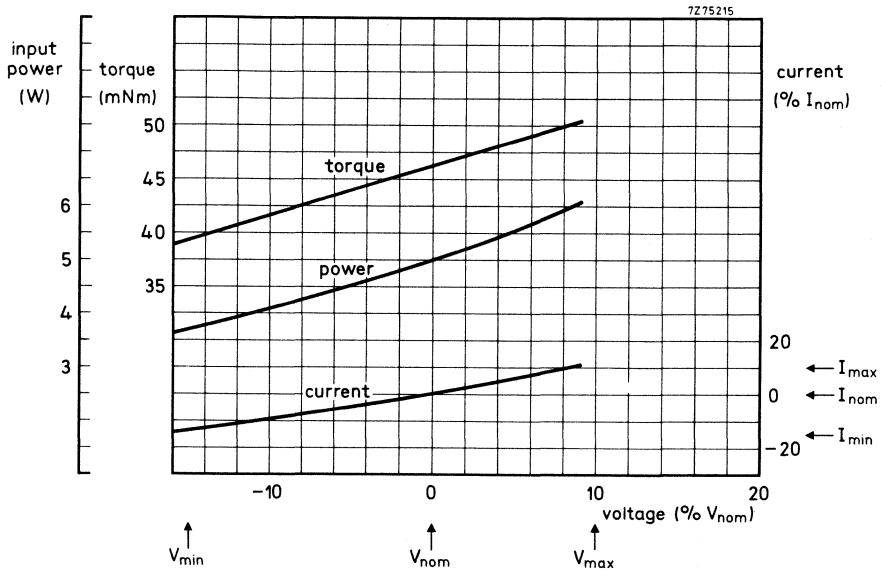

Fig. 3 Typical curves.

REVERSIBLE SYNCHRONOUS MOTORS

general purpose

QUICK REFERENCE DATA

Nominal voltage	220 V, 110 V, 48 V or 24 V
Frequency	50/60 Hz
Speed	250/300 rev/min
Input power	6 W
Torque	70 mNm

APPLICATION

These motors are especially suitable for instrument drives, computer peripherals and office machines. They can also be used for medical pumps, and valve drives in central heating and air-conditioning systems.

A phasing capacitor determines the direction of rotation for a 50 Hz supply. For 60 Hz operation the same capacitor can be used in series with a resistor.

TECHNICAL DATA

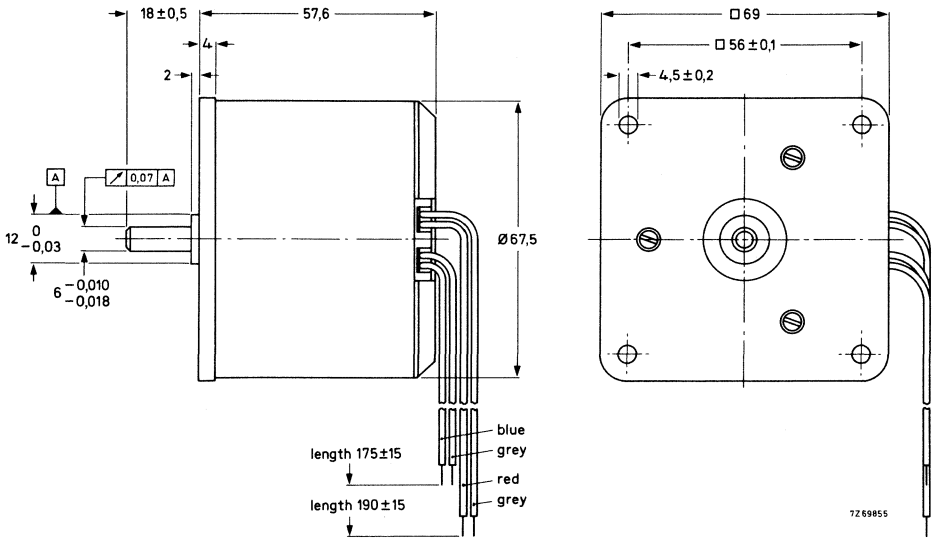

Fig. 1a Version with ϕ 6 mm spindle. The leads are double insulated (AWG22).

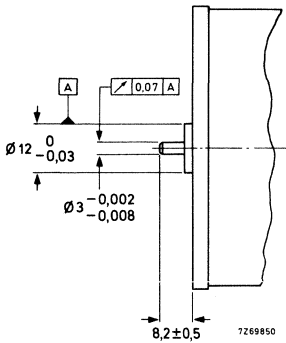

Fig. 1b Version with ϕ 3 mm spindle, for combination with gearbox series 9912 200 00 . . . and . . . 02.

Note: Motors with different voltage ratings are available on request, only in minimum order quantities, and involve longer delivery times than standard versions.

	catalogue number 9904 111 27 . . .				
	111	311	411	511	
versions with spindle ϕ 6 mm	101	301	401	501	
versions with spindle ϕ 3 mm					
Nominal voltage	220	110	48	24	V
Frequency	50	50	50	50	Hz
Speed	250	250	250	250	rev/min
Current	30	55	125	250	mA
Input power	6				W
Starting torque	60				mNm
Working torque	70				mNm
Torque derating	0,4				%/K
Temperature rise of the motor	55				K
Ambient temperature range					
operating	-20 to + 70				$^{\circ}$ C
storage	-40 to + 100				$^{\circ}$ C
Permissible voltage fluctuations	-15 to + 10				%
Insulation test voltage	class 2				
Insulation test voltage	2500				V
Bearings	ball (front), sintered bronze slide (rear)				
Maximum radial force	50				N
Maximum axial force	20				N
Housing	aluminium				
Mass	530				g
Required phasing capacitor	0,22	0,82	4,7	18	μ F
permissible a.c. voltage	330	250	160	100	V

For operation from 60 Hz mains voltage (resulting in a motor speed of 300 rev/min), a resistor must be connected in series with the phasing capacitor; the value of this resistor is:

- 2,7 k Ω , 5 W for 220 V, 60 Hz;
- 1 k Ω , 5 W for 117 V, 60 Hz;
- 39 Ω , 5 W for 48 V, 60 Hz;
- 15 Ω , 5 W for 24 V, 60 Hz.

Connections

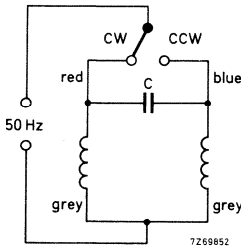

Fig. 2a Connection of the phasing capacitor.

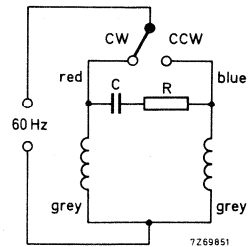

Fig. 2b Connection of a resistor in series with the phasing capacitor for 60 Hz mains supply.

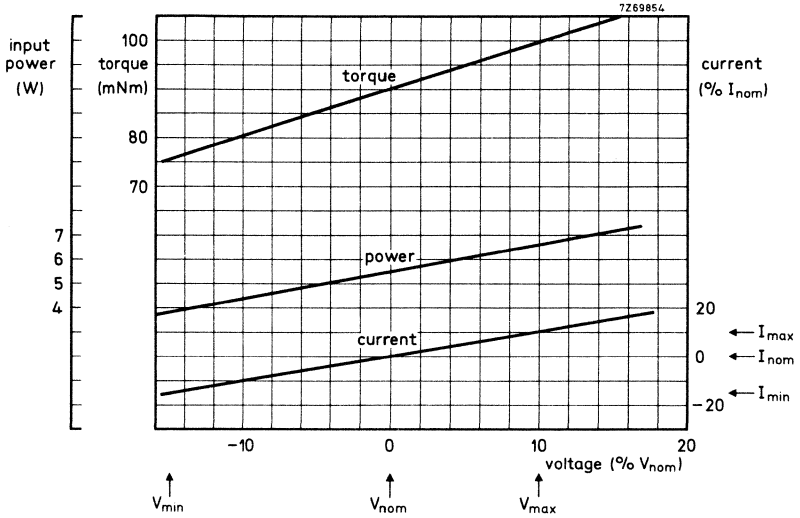

Fig. 3a Typical curves for 50 Hz operation.

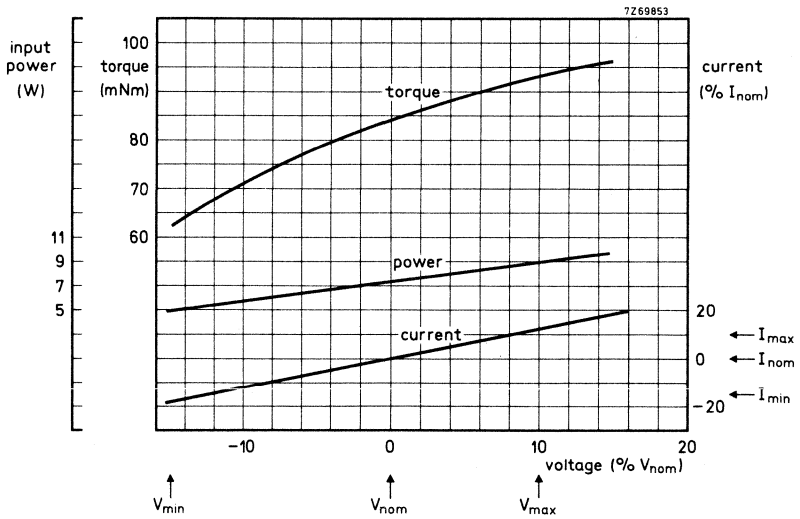

Fig. 3b Typical curves for 60 Hz operation.

REVERSIBLE SYNCHRONOUS MOTORS

special purpose

QUICK REFERENCE DATA

Nominal voltage	220 V, 110 V, 48 V or 24 V
Frequency	50 Hz
Speed	500 rev/min
Input power	15 W
Duty cycle	50%
Torque	70 mNm

APPLICATION

These motors are designed to handle 15 watt input power at 50% duty cycle. This offers an output torque of 70 mNm at 500 rev/min. These properties combined with the closed encapsulation make these motors very suitable for those applications where high torque at a high radial force under severe environmental conditions are required.

Application examples:

- medical pumps,
- valve drives for central heating and air conditioning systems,
- control functions in printing machines.

TECHNICAL DATA

Outlines

Dimensions in mm

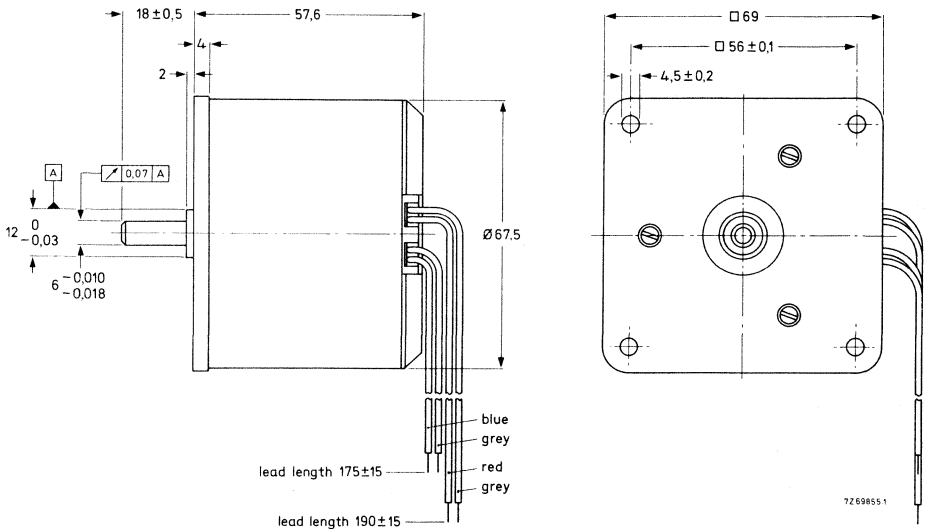

Fig. 1a Version with $\phi 6$ mm spindle. The leads are double insulated (AWG22).

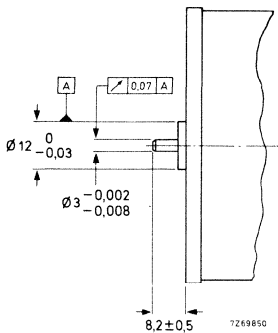

Fig. 1b Version with $\phi 3$ mm spindle, for combination with gearbox series 9912 200 00 . . and . . 02.

	catalogue number 9904 111 28 . . .				
	111	311	411	511	
versions with spindle ϕ 6 mm	101	301	401	501	
Nominal voltage	220	110	48	24	V
Current	70	150	320	600	mA
Frequency		50			Hz
Speed		500			rev/min
Input power		15			W
Working torque		70			mNm
Torque derating		0,4			%/K
Temperature rise of the motor at 50% duty cycle		70			K
Ambient temperature range operating		-20 to + 50			$^{\circ}$ C
storage		-40 to + 100			$^{\circ}$ C
Permissible voltage fluctuations		-15 to + 10			%
Insulation according to CEE10		class 2			
Insulation test voltage		2500			V
Bearings		ball (front), sintered bronze slide (rear)			
Maximum radial force		50			N
Maximum axial force		20			N
Housing		aluminium			
Mass		530			g
Required phasing capacitor C (Fig. 2)	0,56	2,2	12	47	μ F
permissible a.c. voltage	330	250	160	100	V

Connections

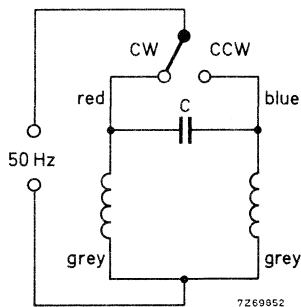

Fig. 2 Connection of the phasing capacitor.

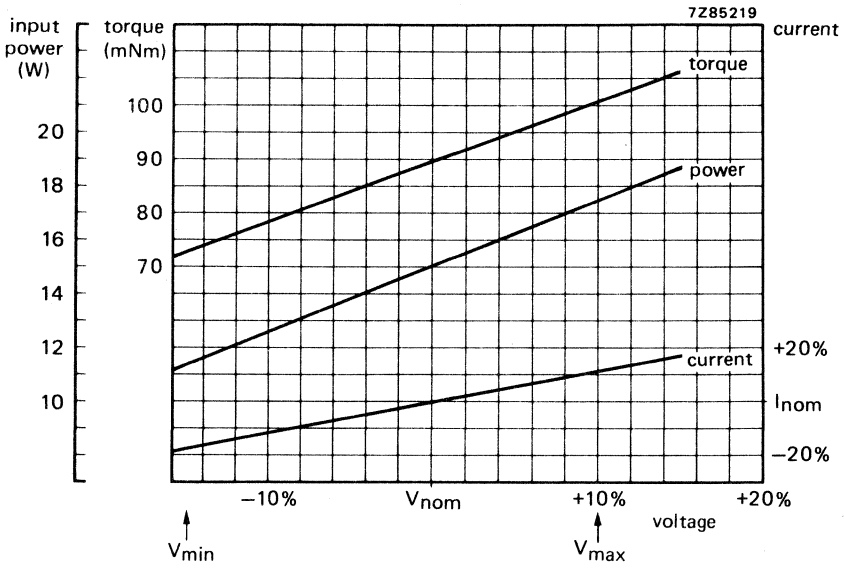

Fig. 3 Typical curves for 50 Hz operation.

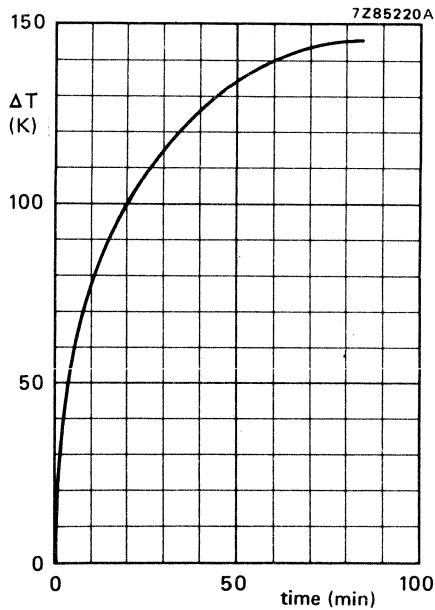

Fig. 4 Temperature increase of the motor versus time of operation.

REVERSIBLE SYNCHRONOUS MOTOR

special purpose

QUICK REFERENCE DATA

Nominal voltage	220 V
Frequency	50 Hz
Speed	500 rev/min
Input power	25 W
Torque	130 mNm
Duty cycle	50%

APPLICATION

These motors are especially suitable for driving heavy loads via a gearbox. When switched-off they have a high detent torque to hold the load in position. They are, therefore, mainly used to drive video camera platforms in surveillance systems. Other applications are:

- control of butterfly valves in airflow systems;
- transmission drive in automation equipment;
- test tube transport in analytical equipment.

TECHNICAL DATA

Outlines

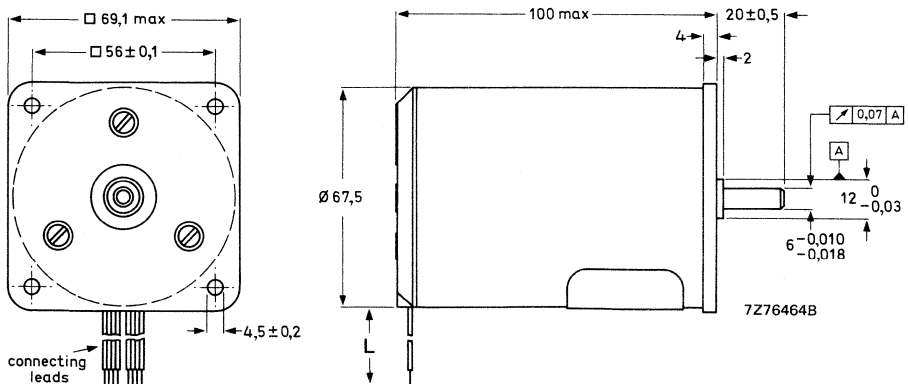

Fig. 1.

L see next page.

catalogue number 9904 111 30112

Nominal voltage	220*	V
Frequency	50	Hz
Speed	500	rev/min
Current	110	mA
Input power	25	W
Detent torque	70	mNm
Working torque	130	mNm
Torque derating	0,4	%/K
Temperature rise of the motor at 50% duty cycle	70	K
Ambient temperature range		
operating	-20 to + 50	°C
storage	-40 to + 100	°C
Duty cycle	50	%
Permissible voltage fluctuations	-15 to + 10	%
Insulation according to CEE10	class 2	
Insulation test voltage	2500	V
Bearings	ball (front), slide (rear)	
Maximum radial force	50	N
Maximum axial force	20	N
Housing	aluminium	
Mass	1100	g
Required phasing capacitor	0,82	μF
permissible a.c. voltage	400	V

* Motors with different voltage ratings are available on request, only in minimum order quantities, and involve longer delivery times.

Connections

Two groups of leads with the same colour coding protrude sideways from the rear motor cover. They can be distinguished by the length.

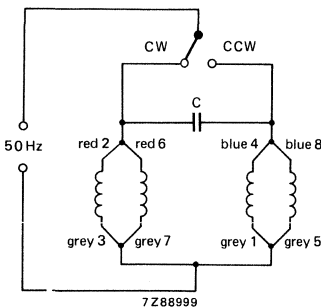

L (see Fig. 1)	colour (see Fig. 2)
135	blue 8
135	grey 7
150	red 6
150	grey 5
165	blue 4
165	grey 3
180	red 2
180	grey 1

Fig. 2 Connecting of the phasing capacitor.

REVERSIBLE SYNCHRONOUS MOTOR

special purpose

QUICK REFERENCE DATA

Nominal voltage	110 V
Frequency	50/60 Hz
Speed	250/300 rev/min
Input power	1,8 W
Torque	10 mNm

APPLICATION

This motor is especially designed to drive the turntable of record players. The design is similar to that of the other motors of the 9904 111 31 . . . series, apart from the rotor and rear bearing construction.

DESCRIPTION

This synchronous motor has a 24-pole permanent magnet rotor the dimensions of which are optimized for low noise running characteristics.
A thrust bearing is used in the rear of the motor assembly for minimum rumble effect. Consequently, the motor mounting position is vertical with the spindle facing upwards.

TECHNICAL DATA

Dimensions in mm

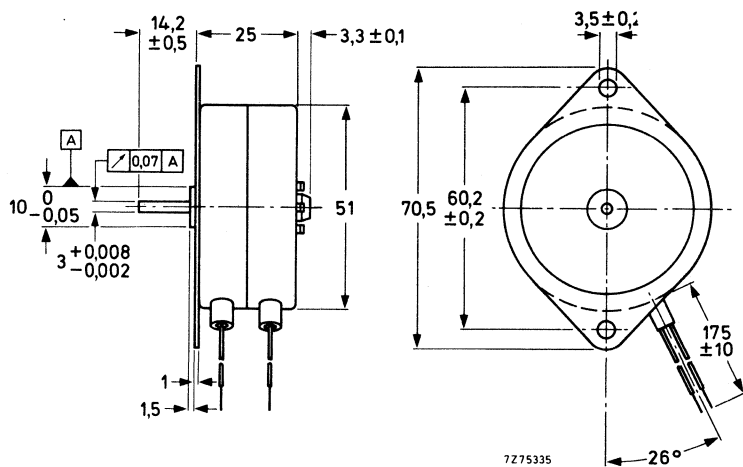

Fig. 1 Motor 9904 111 31302; the leads are double insulated (AWG22).

Nominal voltage	110 V
Frequency	50 Hz
Speed	250 rev/min
Current	18 mA
Input power	1,8 W
Starting torque	10 mNm
Working torque	10 mNm
Torque derating	0,6%/K
Temperature rise of the motor	30 K
Ambient temperature range	
operating	-5 to + 50 °C
storage	-20 to + 70 °C
Permissible voltage fluctuations	-15 to + 10%
Insulation according to CEE10	class 1
Insulation test voltage	2500 V
Bearings	sintered bronze slide (front), polyamide thrust (rear)
Maximum radial force	3 N
Maximum axial force	0,5 N
Housing	zinc plated or tinned
Mass	160 g
Mounting position	spindle upwards
Required phasing capacitor	0,2 μ F \pm 10%
permissible a.c. voltage	250 V

Notes

1. For operation from 117 V, 60 Hz mains voltage (resulting in a motor speed of 300 rev/min), a phasing capacitor of 0,18 μ F \pm 10%/250 V (a.c.) should be used.
2. For operation from 220 V, 50 Hz mains voltage, a series resistor of 6,8 k Ω , 2,5 W should be used (Fig. 3).

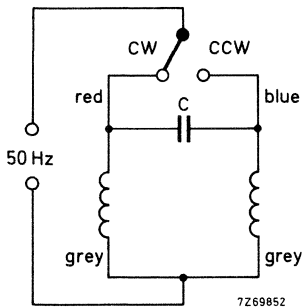

Fig. 2 Connection of the phasing capacitor.

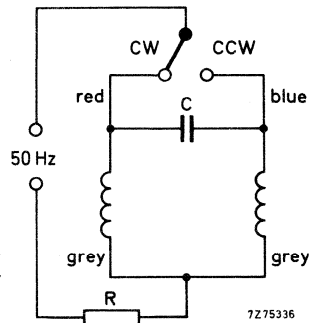

Fig. 3 Connection of the series resistor.

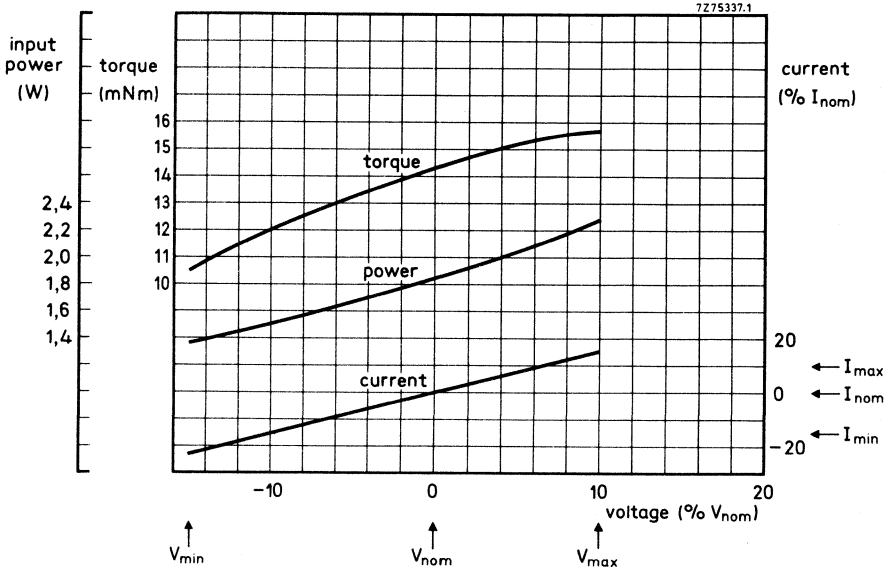

Fig. 4 Typical curves.

REVERSIBLE SYNCHRONOUS MOTORS

general purpose

QUICK REFERENCE DATA

Nominal voltage	220 V, 110 V, 48 V or 24 V
Frequency	50/60 Hz
Speed	250/300 rev/min
Input power	3,5 W
Torque	20 mNm

APPLICATION

These motors are especially suitable for a.c. servo systems where instant start/stop and reversibility of the motor is required. They give maximum torque with parallel coils. This allows for break-before-make switching which ensures instant start/stop and reversal.

A phasing capacitor determines the direction of rotation for a 50 Hz supply. For 60 Hz operation the same capacitor can be used in series with a resistor.

DESCRIPTION

The motors 9904 111 31 . . 1 have coils with double-insulated flying leads. Insulation satisfies CEE10 class 2.

TECHNICAL DATA

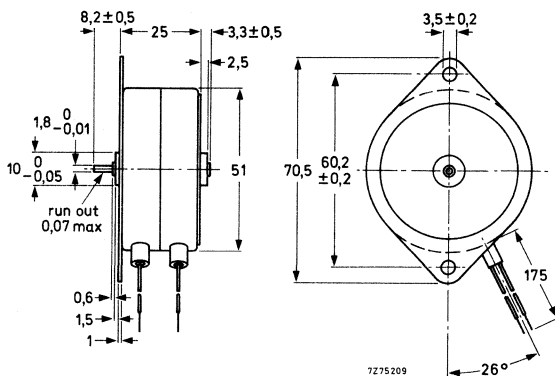

Fig. 1 Version with ϕ 1,8 mm spindle. The leads are double insulated (AWG24).

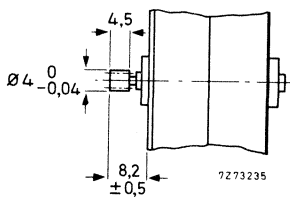

Fig. 2 Version with pinion.
 number of teeth = 10;
 module = 0,3;
 addendum modification = + 0,2.

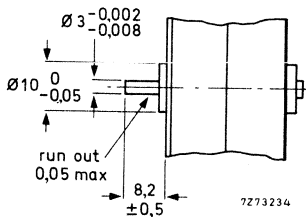

Fig. 3 Version with ϕ 3 mm spindle.

	catalogue number 9904 111 31 . . 1				
	11	31	41	51	
versions with spindle ϕ 1,8 mm	11	31	41	51	
versions with spindle ϕ 3 mm	10	30	40	50	
versions with pinion	13	33	43	53	
Nominal voltage	220	110	48	24	V
Frequency	50	50	50	50	Hz
Speed	250	250	250	250	rev/min
Current	16	30	80	150	mA
Input power		3,5			W
Starting torque		20			mNm
Working torque		20			mNm
Torque derating		0,4			%/K
Temperature rise of the motor		60			K
Ambient temperature range					
operating		-20 to + 60			°C
storage		-40 to + 100			°C
Permissible voltage fluctuations		-15 to + 10			%
Insulation according to CEE10		class 2			
Insulation test voltage		2500			V
Bearings		sintered bronze slide			
Maximum radial force		5			N
Maximum axial force		1,5			N
Housing		zinc plated			
Mass		160			g
Required phasing capacitor	0,1	0,39	2,2	8	μ F
permissible a.c. voltage	330	350	160	63	V

For operating from 60 Hz mains voltage (resulting in a motor speed of 300 rev/min), a resistor must be connected in series with the phasing capacitor; the value of this resistor is:

1,8 k Ω , 0,5 W for 220 V, 60 Hz;

560 Ω , 0,5 W for 117 V, 60 Hz;

68 Ω , 0,5 W for 48 V, 60 Hz.

No resistor is required for operation from a 24 V, 60 Hz supply.

Connections

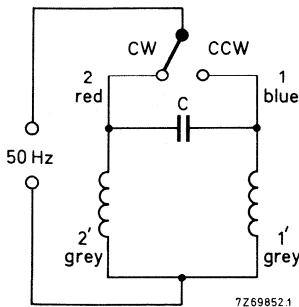

Fig. 4.

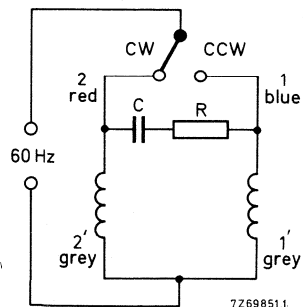

Fig. 5.

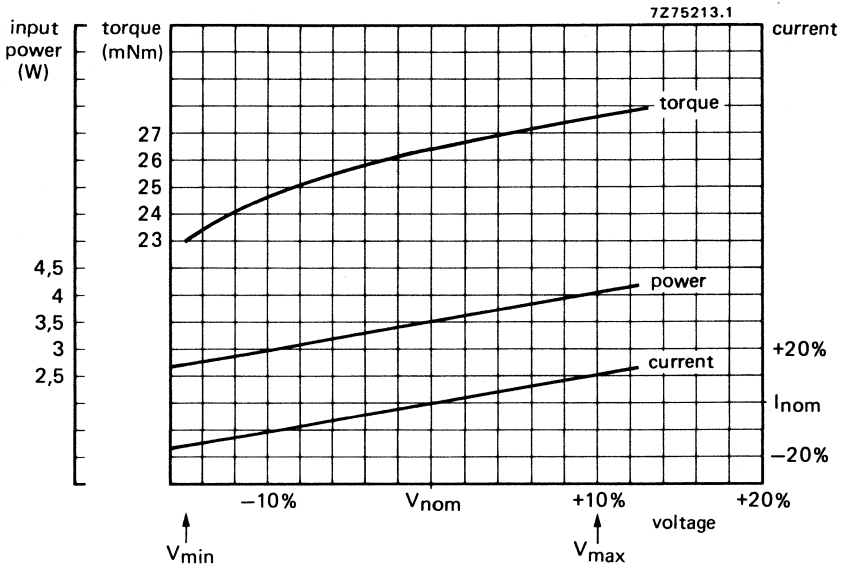

Fig. 6 Typical curves for 50 Hz operation.

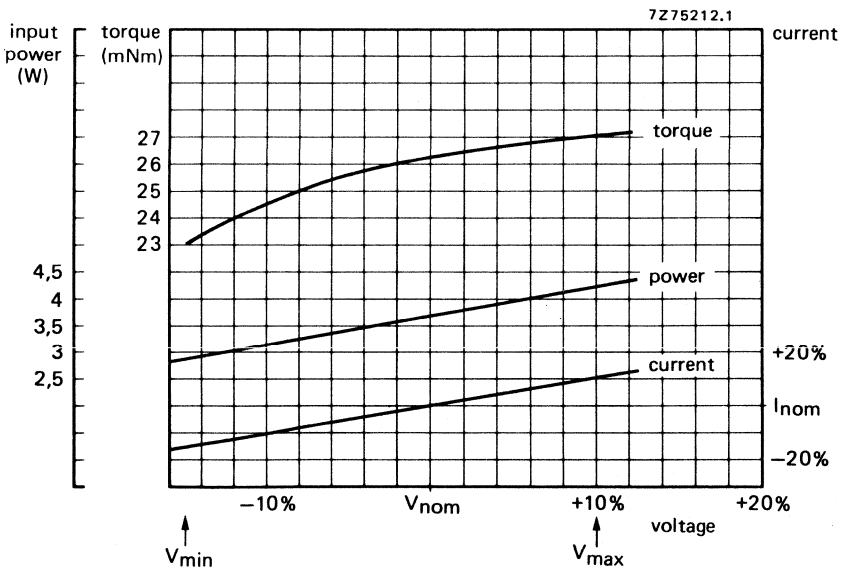

Fig. 7 Typical curves for 60 Hz operation.

REVERSIBLE SYNCHRONOUS MOTORS

general purpose, economy version

QUICK REFERENCE DATA

Nominal voltage	220 V, 110 V, 48 V or 24 V
Frequency	50/60 Hz
Speed	250/300 rev/min
Input power	3,5 W
Torque	20 mNm

APPLICATION

These motors are especially suitable for a.c. servo systems where instant start/stop and reversibility of the motor is required. They give maximum torque with parallel coils. This allows for break-before-make switching which ensures instant start/stop and reversal.

A phasing capacitor determines the direction of rotation for a 50 Hz supply. For 60 Hz operation the same capacitor can be used in series with a resistor.

DESCRIPTION

The economy series 9904 111 31 . . 4 has coils with soldering tags that protrude sideways from the motor body to allow for automated production. Insulation satisfies CEE10 class 1.

Economy type

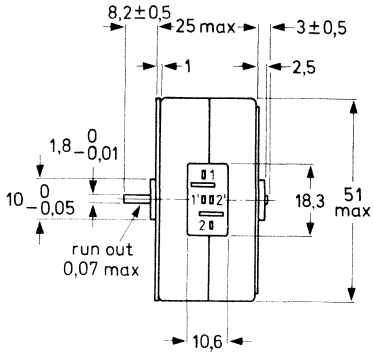

Fig. 1 Version with ϕ 1,8 mm spindle.

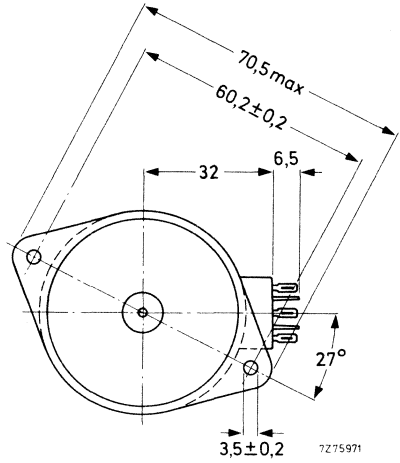

Fig. 2 Version with pinion.
 number of teeth = 10;
 module = 0,3;
 addendum modification = + 0,2.

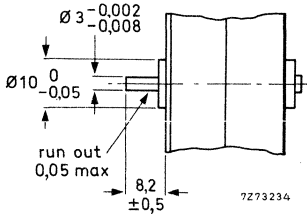
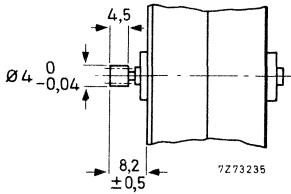

Fig. 3 Version with ϕ 3 mm spindle.

	catalogue number 9904 111 31 . . 4				
	11	31	41	51	
versions with spindle ϕ 1,8 mm	10	30	40	50	
versions with spindle ϕ 3 mm	13	33	43	53	
versions with pinion					
Nominal voltage	220	110	48	24	V
Frequency	50	50	50	50	Hz
Speed	250	250	250	250	rev/min
Current	16	30	80	150	mA
Input power		3,5			W
Starting torque		20			mNm
Working torque		20			mNm
Torque derating		0,4			%/K
Temperature rise of the motor		60			K
Ambient temperature range					
operating		-20 to + 60			°C
storage		-40 to + 100			°C
Permissible voltage fluctuations		-15 to + 10			%
Insulation according to CEE10		class 1			
Insulation test voltage		1500			V
Bearings		sintered bronze slide			
Maximum radial force		5			N
Maximum axial force		1,5			N
Housing		zinc plated			
Mass		160			g
Required phasing capacitor	0,1	0,39	2,2	8	μ F
permissible a.c. voltage	330	350	160	63	V

For operating from 60 Hz mains voltage (resulting in a motor speed of 300 rev/min), a resistor must be connected in series with the phasing capacitor; the value of this resistor is:

1,8 k Ω , 0,5 W for 220 V, 60 Hz;

560 Ω , 0,5 W for 117 V, 60 Hz;

68 Ω , 0,5 W for 48 V, 60 Hz.

No resistor is required for operation from a 24 V, 60 Hz supply.

Connections

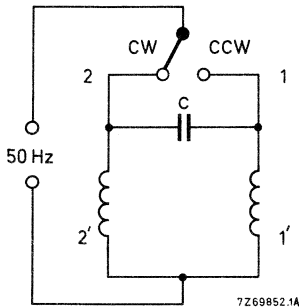

Fig. 4.

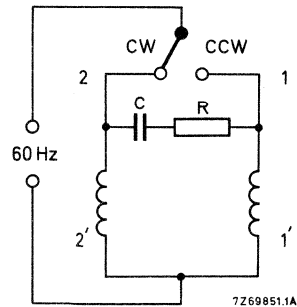

Fig. 5.

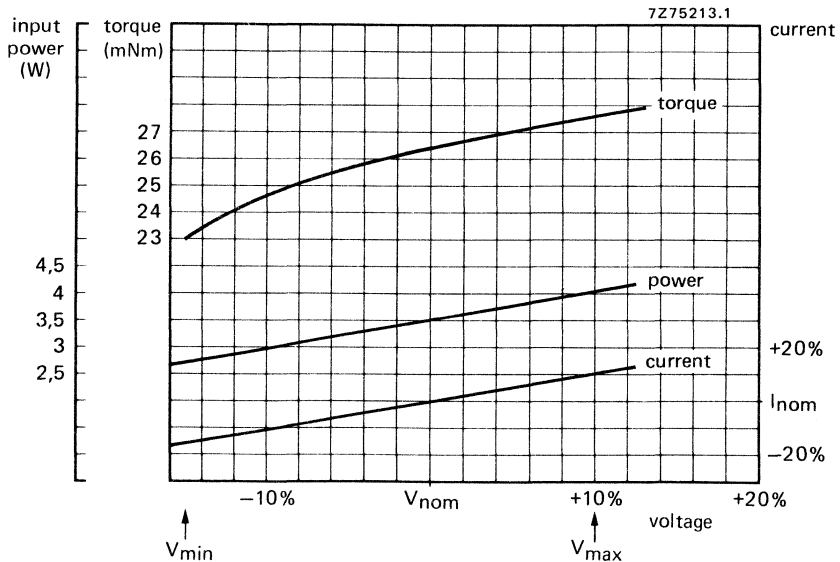

Fig. 6 Typical curves for 50 Hz operation.

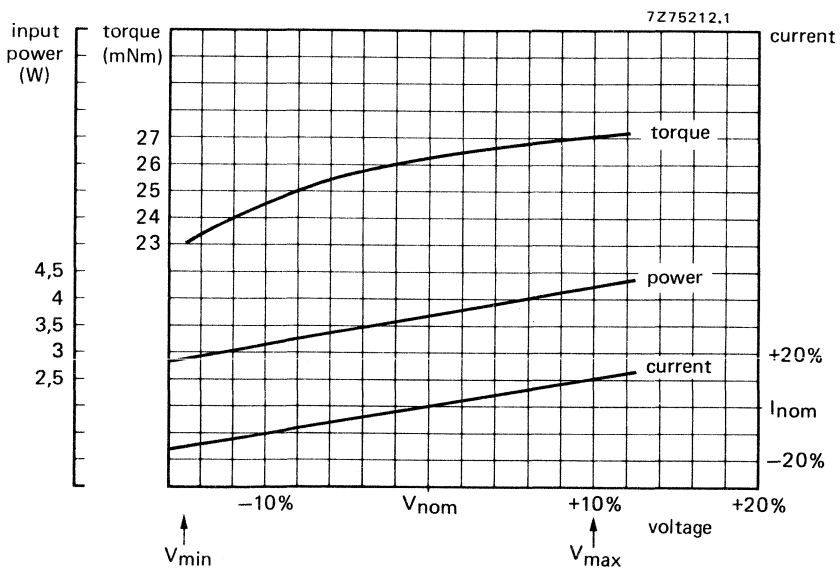

Fig. 7 Typical curves for 60 Hz operation.

REVERSIBLE SYNCHRONOUS MOTORS

general purpose

QUICK REFERENCE DATA

Nominal voltage			
coils in parallel	110/117 V	48 V	24 V
coils in series	220 V	110/117 V	48 V
Frequency		50/60 Hz	
Speed		250/300 rev/min	
Input power			
coils in parallel		0,8 W	
coils in series		1,7 W	
Torque			
coils in parallel		4 mNm	
coils in series		7 mNm	

APPLICATION

These motors have been designed for optimum performance in equipment with limited available space but where high torque and reversibility of the motor is required. To keep the dimensions as small as possible, the coils are connected in series for 220 V operation. The motors find application in control and regulating systems in instrumentation.

TECHNICAL DATA

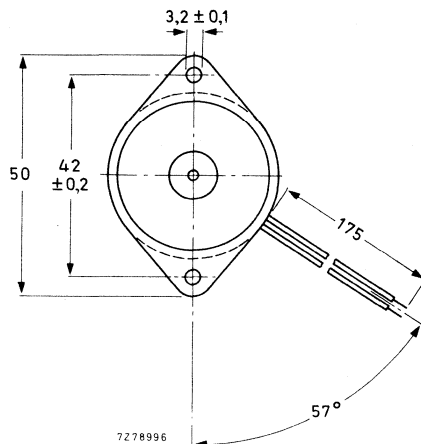
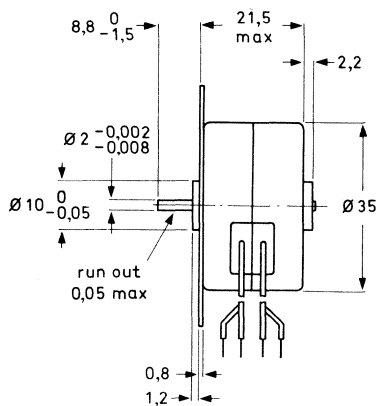

Fig. 1 Version with ϕ 2 mm spindle. The leads are double insulated (AWG24).

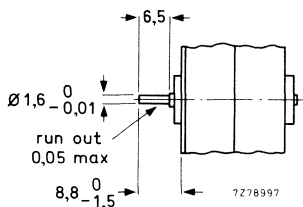

Fig. 2 Version with ϕ 1,6 mm spindle.

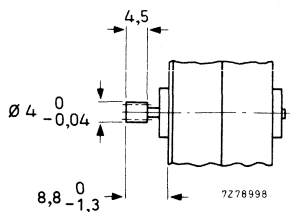

Fig. 3 Version with pinion
 number of teeth = 10
 module = 0,3
 addendum modification = + 0,2.

	catalogue number 9904 111 32 . . 1							
	coils in parallel			coils in series				
version with spindle ϕ 2 mm	31	41	51	31	41	51		
version with spindle ϕ 1,6 mm	32	42	52	32	42	52		
version with pinion	33	43	53	33	43	53		
Nominal voltage	110/117	48	24	220	110/117	48	V	
Frequency		50/60			50/60		Hz	
Speed		250/300			250/300		rev/min	
Current	8	18	35	8	18	35	mA	
Input power		0,8			1,7		W	
Working torque		4			7		mNm	
Torque derating		0,4			0,4		%/K	
Temperature rise of the motor		30			50		K	
Ambient temperature range		-20 to + 70			-20 to + 60			$^{\circ}$ C
operating								$^{\circ}$ C
storage					-40 to + 100			$^{\circ}$ C
Permissible voltage fluctuations					+ 10 to - 15			%
Insulation according to CEE10					class 1			
Insulation test voltage					1500			V
Bearings					sintered bronze slide			
Maximum radial force					2,5			N
Maximum axial force					0,75			N
Housing					zinc plated			
Mass					80			g
Required phasing capacitor	0,1	0,56	2,2	0,22	1*	4,7	μ F	
permissible a.c. voltage	250	160	63	250	160	160	V	

Connections

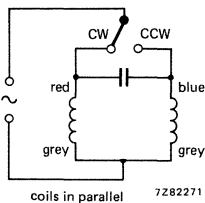

Fig. 4.

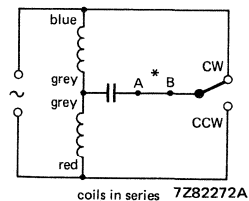

Fig. 5.

* For 60 Hz operation, resistor 680 Ω 0,5 W required between A and B. Type 9904 111 324 . . only.

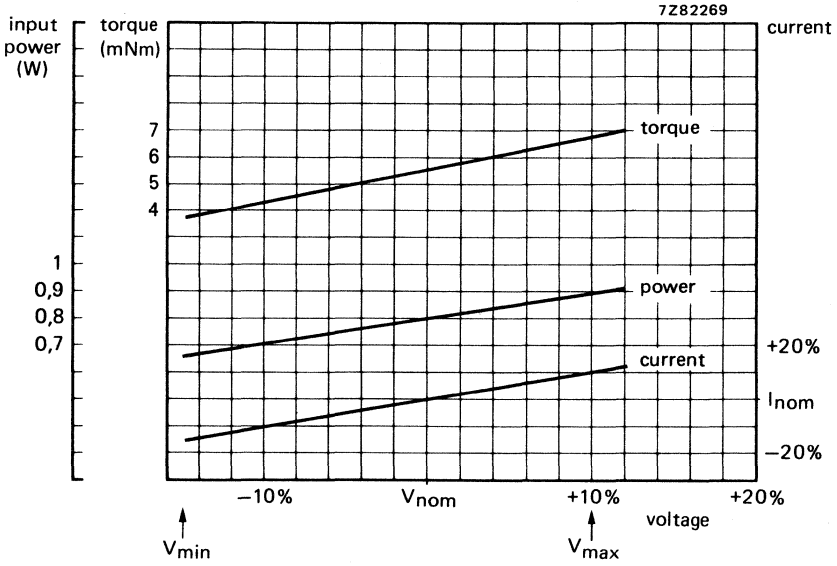

Fig. 6 Typical curves; coils in parallel.

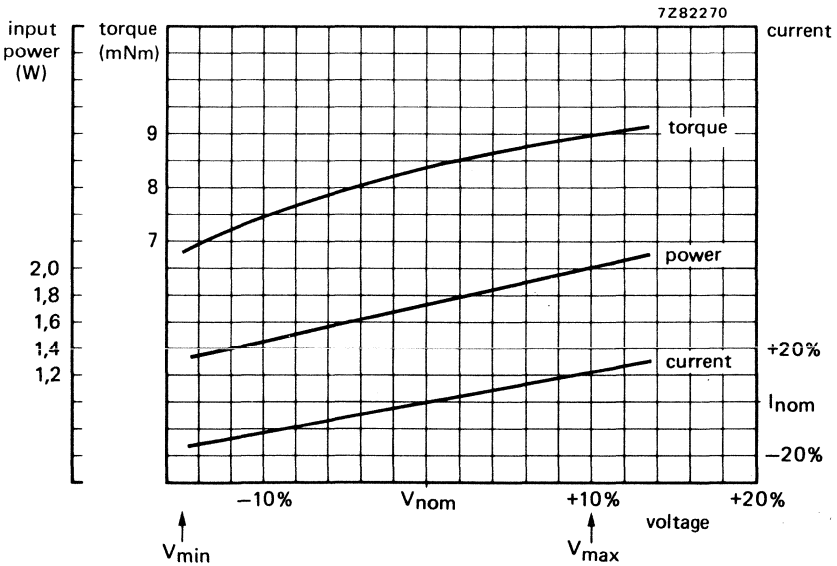

Fig. 7 Typical curves; coils in series.

REVERSIBLE SYNCHRONOUS MOTORS

general purpose, economy version

QUICK REFERENCE DATA

Nominal voltage			
coils in parallel	110/117 V	48 V	24 V
coils in series	220 V	110/117 V	48 V
Frequency		50/60 Hz	
Speed		250/300 rev/min	
Input power			
coils in parallel		0,8 W	
coils in series		1,7 W	
Torque			
coils in parallel		3,2 mNm	
coils in series		6 mNm	

APPLICATION

These motors have been designed for optimum performance in equipment with limited available space but where high torque and reversibility of the motor is required. To keep the dimensions as small as possible, the coils are connected in series for 220 V operation. The motors find application in control and regulating systems in instrumentation.

DESCRIPTION

The economy version has a coil concept with soldering tags protruding sideways from motorbody allowing automated production. Insulation satisfies CEE10 class 1.

TECHNICAL DATA

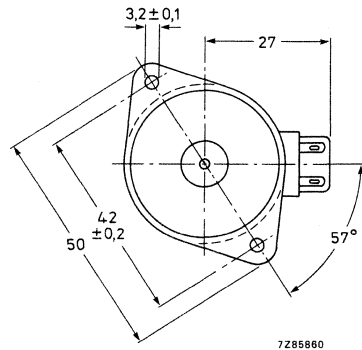
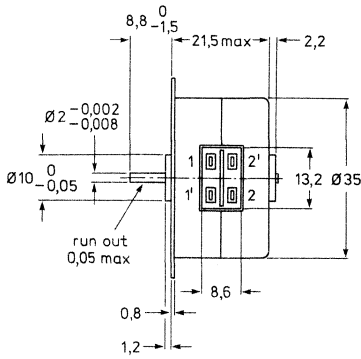

Fig. 1 Version with ϕ 2 mm spindle for combination with gearbox 9912 200 01... series.

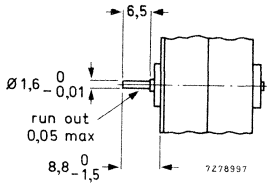

Fig. 2 Version with ϕ 1,6 mm spindle.

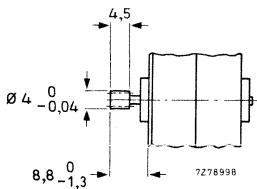

Fig. 3 Version with pinion number of teeth = 10; module = 0,3 addendum modification = + 0,2.

	catalogue number 9904 111 32 . . 4						
	coils in parallel			coils in series			
version with spindle ϕ 2 mm	31	41	51	31	41	51	
version with spindle ϕ 1,6 mm	32	42	52	32	42	52	
version with pinion	33	43	53	33	43	53	
Nominal voltage	110/117	48	24	220	110/117	48	V
Frequency		50/60			50/60		Hz
Speed		250/300			250/300		rev/min
Current	8	18	35	8	18	35	mA
Input power		0,8			1,7		W
Working torque		3,2			6		mNm
Torque derating		0,4			0,4		%/K
Temperature rise of the motor		30			50		K
Ambient temperature range							$^{\circ}$ C
operating		-20 to + 70			-20 to + 60		$^{\circ}$ C
storage					-40 to + 100		$^{\circ}$ C
Permissible voltage fluctuations					+ 10 to - 15		%
Insulation according to CEE10					class 1		
Insulation test voltage					1500		V
Bearings					sintered bronze slide		
Maximum radial force					2,5		N
Maximum axial force					0,75		N
Housing					zinc plated		
Mass					80		g
Required phasing capacitor	0,1	0,56	2,2	0,22	1*	4,7	μ F
permissible a.c. voltage	250	160	63	250	160	160	V

Connections

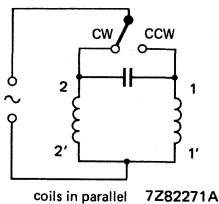

Fig. 4.

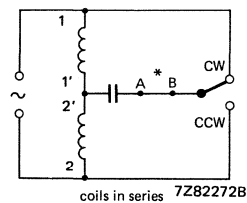

Fig. 5.

* For 60 Hz operation, resistor 680 Ω 0,5 W required between A and B. Type 9904 111 324 . . only.

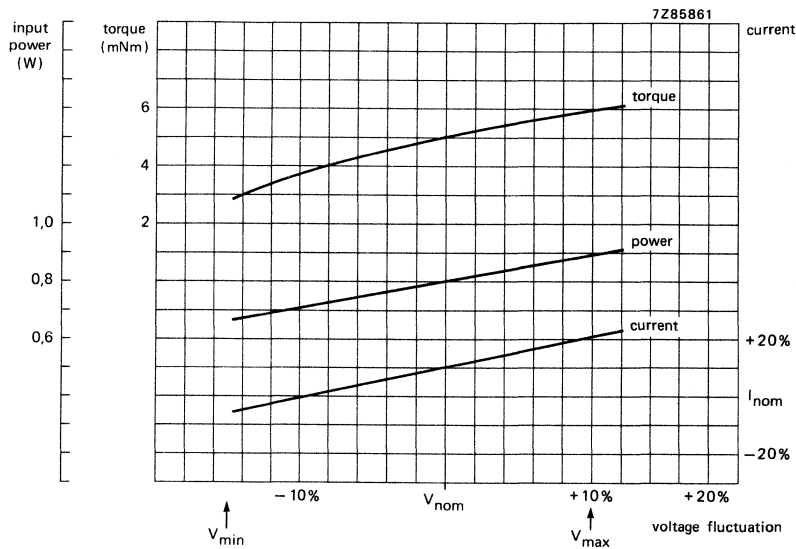

Fig. 6 Typical curves; coils in parallel.

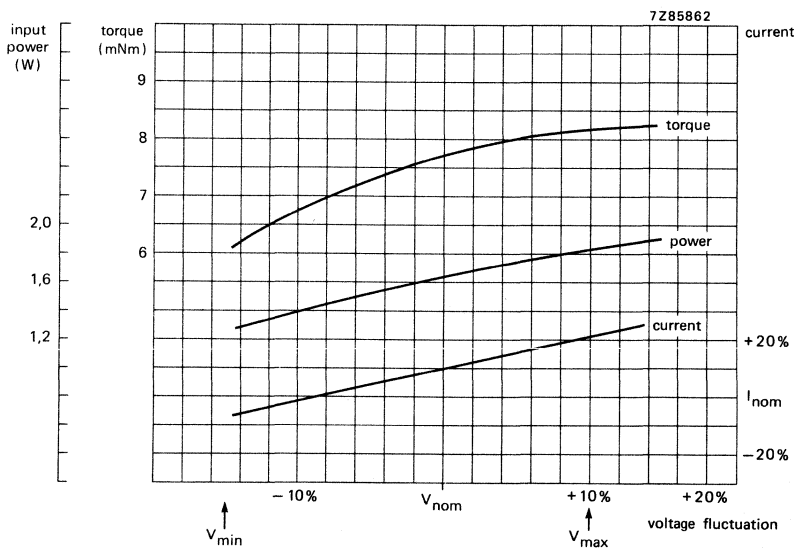

Fig. 7 Typical curves; coils in series.

REVERSIBLE SYNCHRONOUS MOTORS

general purpose, economy version

QUICK REFERENCE DATA

Nominal voltage	220 V, 110 V, 48 V, 24 V
Frequency	50/60 Hz
Speed	250/300 rev/min
Input power	6 W
Torque	70 mNm

APPLICATION

For control functions in central heating and air conditioning systems.

DESCRIPTION

These high-torque synchronous motors have a strictly functional, and therefore economical, design. They are not encapsulated, they have one long sintered iron bearing, and coil formers provided with a connecting block with soldering tags, allowing for automated production. A separate terminal cover is supplied with each motor. This "snap-on" cover provides protection in applications where the solder connections are otherwise accessible.

The insulation meets CEE10 class 1 requirements, fulfilling the majority of international safety requirements.

TECHNICAL DATA

Outlines

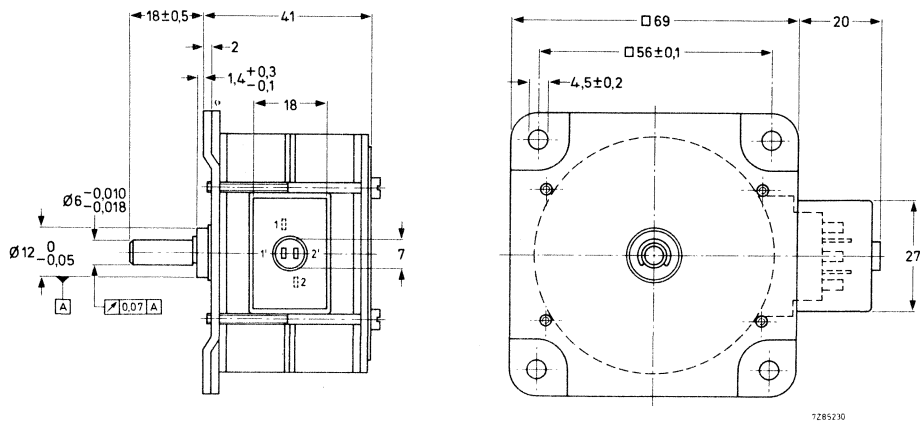

Fig. 1a Version with ϕ 6 mm spindle.

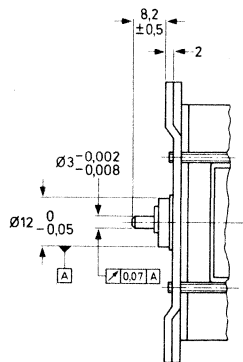

Fig. 1b Version with ϕ 3 mm spindle, for combination with gearbox series 9912 200 00

	catalogue number 9904 111 33 . . 4				
	11 10	31 30	41 40	51 50	
versions with spindle ϕ 6 mm					
versions with spindle ϕ 3 mm					
Nominal voltage	220	110	48	24	V
Current	30	55	140	260	mA
Frequency		50/60			Hz
Speed		250/300			rev/min
Input power		6			W
Working torque		70			mNm
Torque derating		-0,6			%/K
Temperature rise of the motor		55			K
Ambient temperature range					°C
operating		-20 to + 70			°C
storage		-40 to + 100			%
Permissible voltage fluctuations		-15 to + 10			
Insulation according to CEE10		class 1			V
Insulation test voltage		1500			
Bearings		one slide; sintered iron, oil impregnated			
Maximum radial force		10			N
Maximum axial force		5			N
Mass		450			g
Required phasing capacitor C (Figs 2 and 3)	0,22	0,82	4,7	18	μ F
	330	250	160	100	V
Required series resistor R for 60 Hz operation (Fig. 3)	2700	1000	56	18	Ω
	5	5	5	5	W

Connections

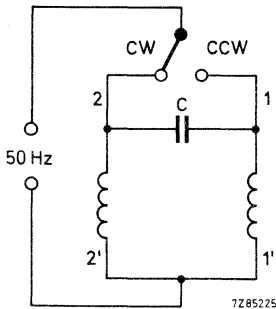

Fig. 2.

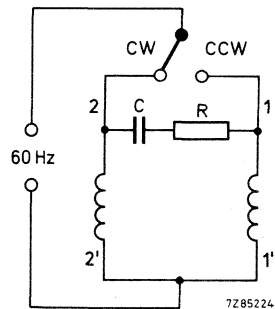

Fig. 3.

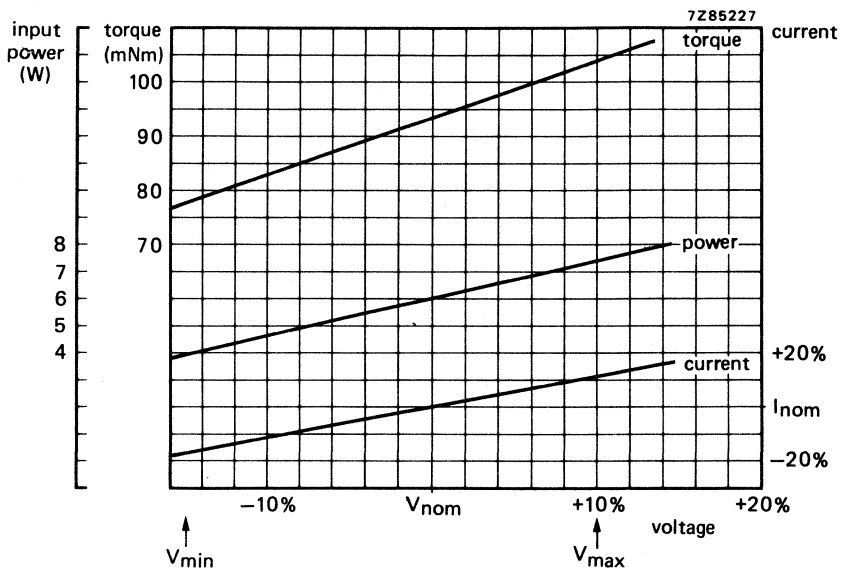

Fig. 4 Typical curves for 50 Hz operation.

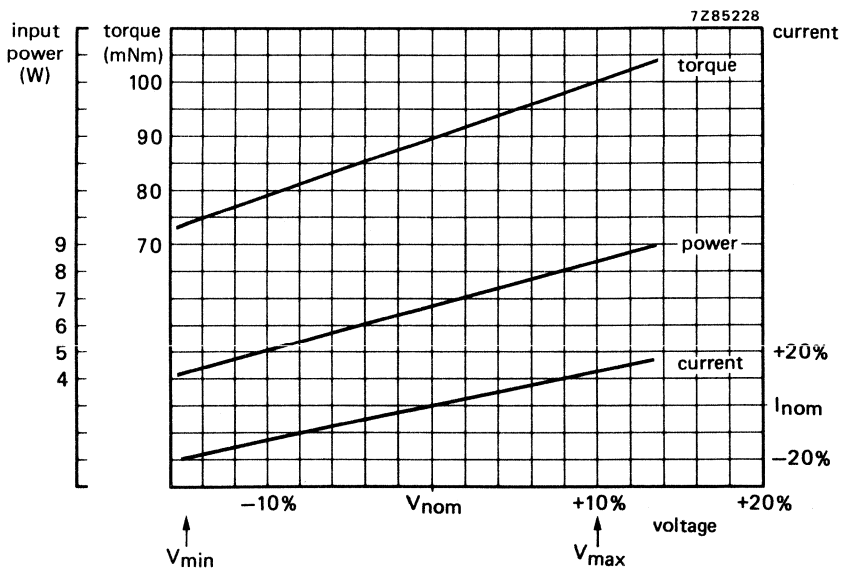

Fig. 5 Typical curves for 60 Hz operation.

REVERSIBLE SYNCHRONOUS MOTORS

economy version, special purpose

QUICK REFERENCE DATA

Nominal voltage	220 V, 110 V, 48 V or 24 V
Frequency	50 Hz
Speed	500 rev/min
Input power	14 W
Duty cycle	50%
Torque	70 mNm

APPLICATION

These motors are very suitable for those applications in which they are not used in a continuous mode, as for valve control and other control functions in central heating and air conditioning systems. Power handling is max. 15 watt input at 50% duty cycle.

DESCRIPTION

These high-torque synchronous motors have a strictly functional, and economical design. They are not encapsulated, have one long sintered iron bearing, and coil formers provided with a connecting block with soldering tags. A separate terminal cover is supplied with each motor. This "snap-on" cover provides protection in applications where the solder connections are otherwise accessible.

The insulation meets CEE10 class 1 requirements, fulfilling the majority of international safety requirements.

TECHNICAL DATA

Outlines

Dimensions in mm

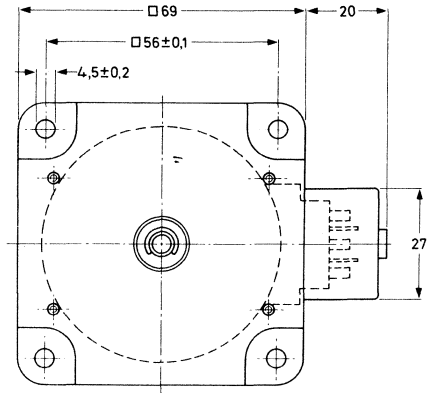
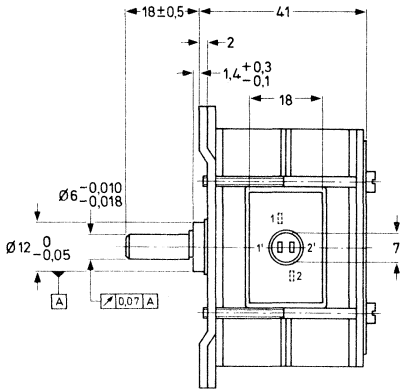

7285230

Fig. 1a Version with ϕ 6 mm spindle.

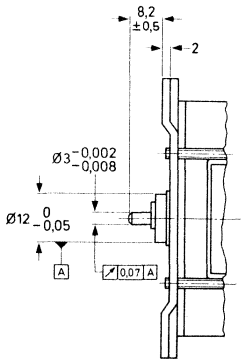

Fig. 1b Version with ϕ 3 mm spindle.

	catalogue number 9904 111 34...				
	114	314	414	514	
versions with spindle ϕ 6 mm	104	304	404	504	
versions with spindle ϕ 3 mm					
Nominal voltage	220	110	48	24	V
Current	65	130	300	520	mA
Frequency		50			Hz
Speed		500			rev/min
Input power		14			W
Working torque		70			mNm
Torque derating		-0,6			%/K
Temperature rise of the motor at 50% duty cycle		70			K
Ambient temperature range					
operating		-20 to + 50			$^{\circ}$ C
storage		-40 to + 100			$^{\circ}$ C
Permissible voltage fluctuations		-15 to + 10			%
Insulation according to CEE10		class 1			
Insulation test voltage		1500			V
Bearings		one slide; sintered iron, oil impregnated			
Maximum radial force		10			N
Maximum axial force		5			N
Mass		450			g
Required phasing capacitor C (Fig. 2)	0,47	1,8	10	35	μ F
	330	250	160	100	V

Connections

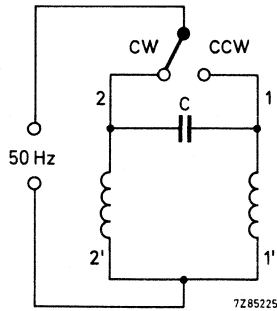

Fig. 2.

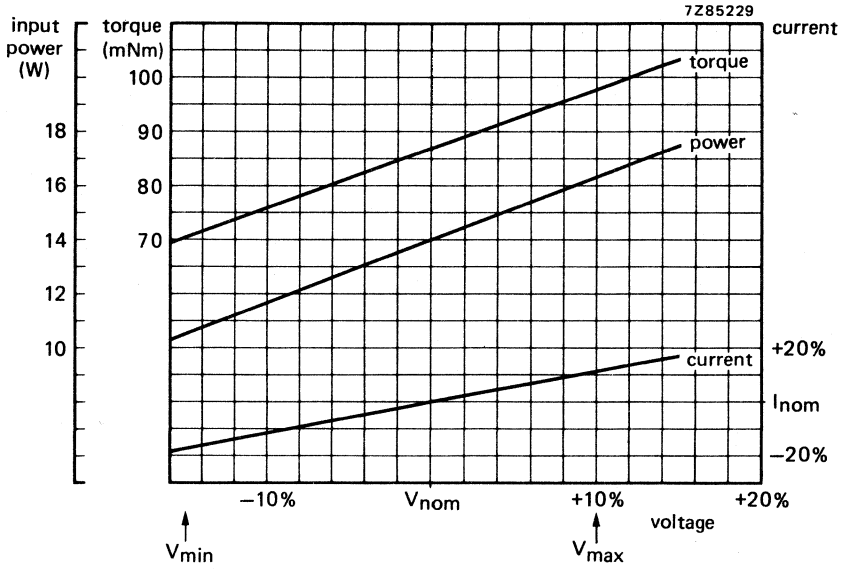

Fig. 3 Typical curves.

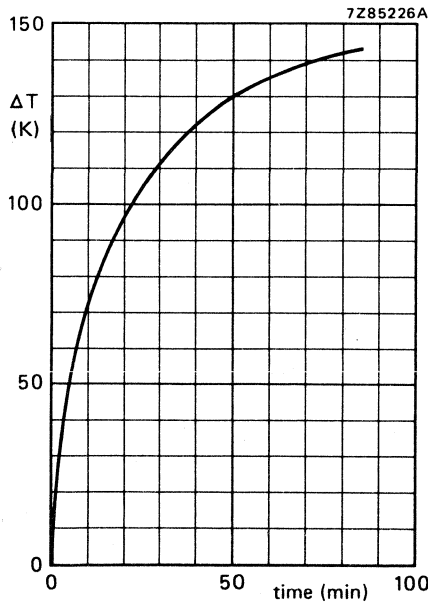

Fig. 4 Temperature increase versus operation time.

REVERSIBLE SYNCHRONOUS MOTORS

general purpose, economy version

QUICK REFERENCE DATA

Nominal voltage	220 V, 110 V, 48 V or 24 V
Frequency	50/60 Hz
Speed	250/300 rev/min
Input power	3,5 W
Torque	33 mNm

APPLICATION

These motors are especially suitable for a.c. servo systems where instant start/stop and reversibility of the motor is required. They have maximum torque output in the parallel connection. This allows for break-before-make switching and ensures instant start/stop and reversals.

A phasing capacitor is used to determine the direction of rotation. Its value is different for 50 Hz and 60 Hz operation.

DESCRIPTION

The motors have a coil concept with soldering tags which protrude sideways from the motor body to allow for automated production. The insulation satisfies CEE10 class 1.

The spindle diameter of 3 mm allows for combination with gearbox series 9912 200 00 . . . and 02

TECHNICAL DATA
 Outlines

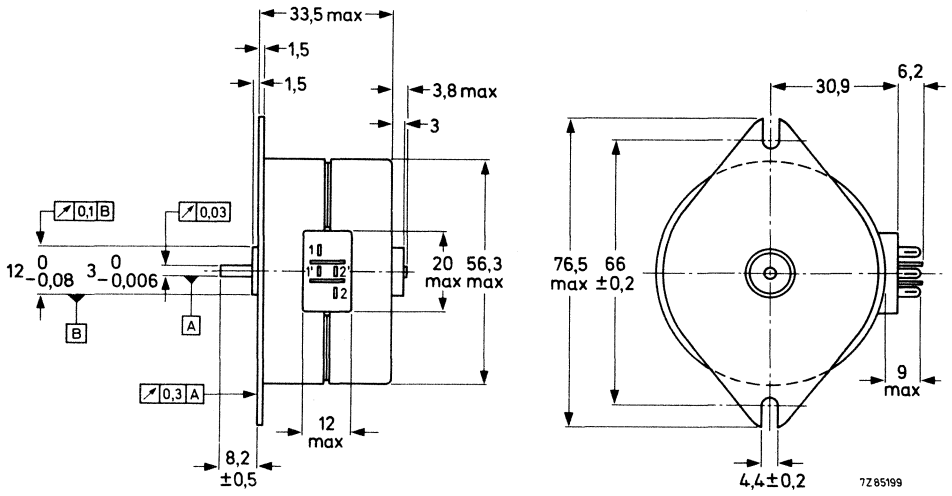

Fig. 1.

The motors are also available with a spindle of $\phi 4$ mm (tol. $-0,008$ mm), length $16 \pm 0,5$ mm.

	catalogue number 9904 111 35 . . 4				
	10	30	40	50	
versions with spindle ϕ 3 mm	11	31	41	51	
versions with spindle ϕ 4 mm					
Nominal voltage	220	110	48	24	V
Current	15	30	80	140	mA
Frequency	50/60				Hz
Speed	250/300				rev/min
Input power	3,5				W
Working torque	33				mNm
Torque derating	-0,4				%/K
Temperature rise of the motor	55				K
Ambient temperature range					
operating	-20 to + 70				$^{\circ}$ C
storage	-40 to + 100				$^{\circ}$ C
Permissible voltage fluctuations	-15 to + 10				%
Insulation according to CEE10	class 1				
Insulation test voltage	1500				V
Bearings	sintered bronze slide				
Maximum radial force	10				N
Maximum axial force	1,5				N
Housing	zinc plated				
Mass	300				g
Required phasing capacitor C (Fig. 2)					
50 Hz operation	0,12	0,47	2,7	10	μ F
60 Hz operation	330	250	160	63	V
	0,1	0,39	2,2	8	μ F
	330	250	160	63	V

Connections

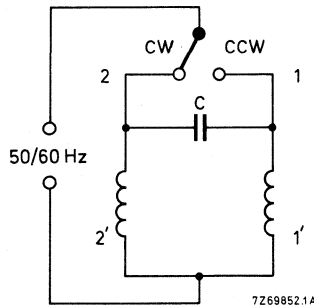

Fig. 2.

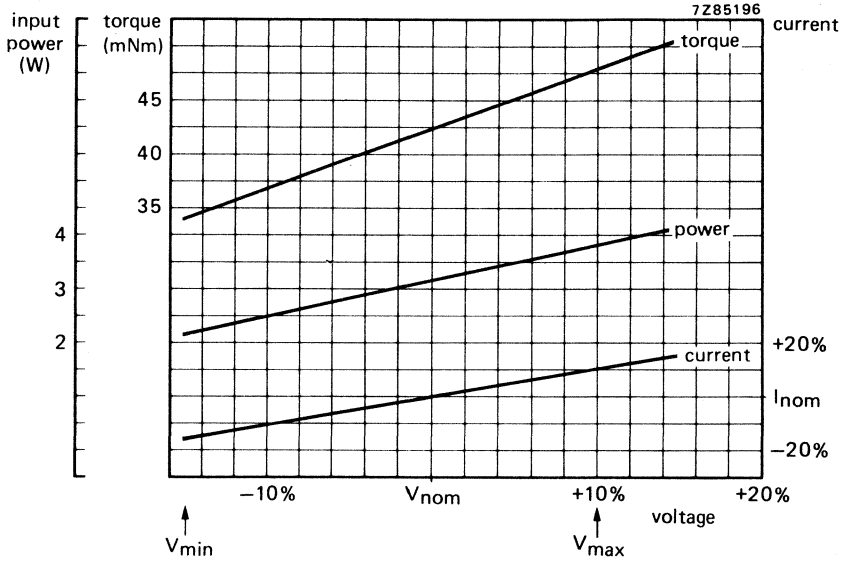

Fig. 3 Typical curves for 50 Hz operation.

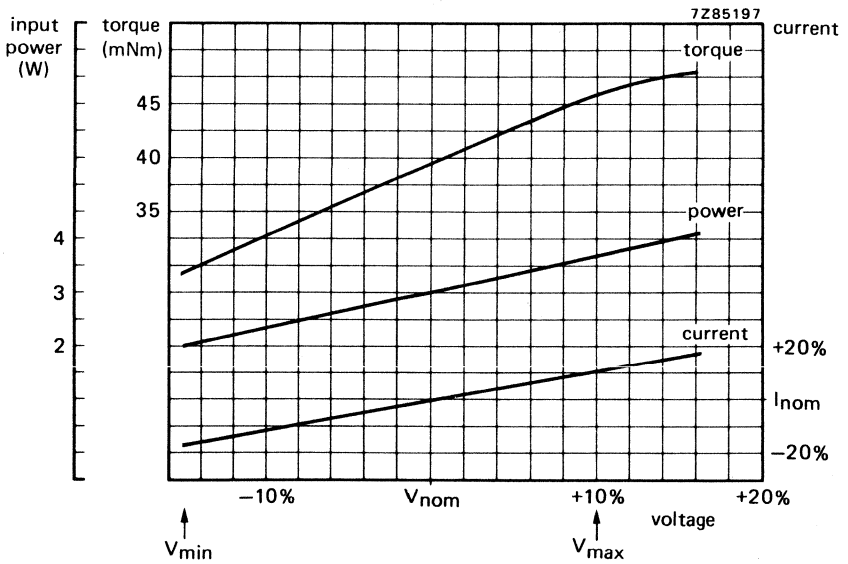

Fig. 4 Typical curves for 60 Hz operation.

REVERSIBLE SYNCHRONOUS MOTORS

economy version, special purpose

QUICK REFERENCE DATA

Nominal voltage	220 V, 110 V, 48 V or 24 V
Frequency	50 Hz
Speed	500 rev/min
Input power	6 W
Torque	33 mNm
Duty cycle	50%

APPLICATION

These motors are especially suitable for a.c. servo systems where instant start/stop and reversibility is required. The maximum output torque at a speed of 500 rev/min is achieved with parallel connected coils. This allows for break-before-make switching and ensures instant start/stop and reversal. Power handling is 6 W input at 50% duty cycle.

A phasing capacitor determines the direction of rotation for a 50 Hz supply. For 60 Hz operation please request application information.

DESCRIPTION

The coils of the motors are electrically connected to four soldering tags which are anchored in the coil former. These tags protrude sideways from the motor body. The insulation satisfies the CEE10 class 1 requirements.

TECHNICAL DATA

Outlines

Dimensions in mm

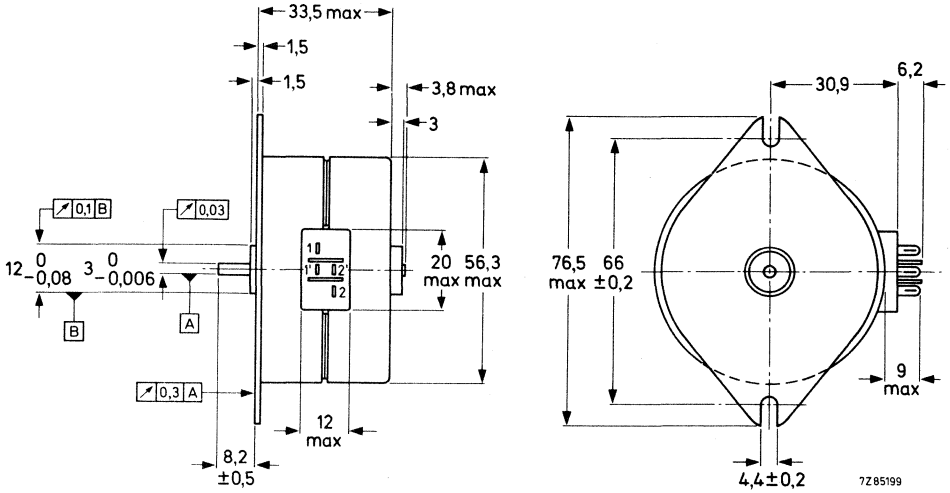

Fig. 1.

The motors are also available with a spindle of $\phi 4$ mm (tol. $-0,008$ mm), length $16 \pm 0,5$ mm.

versions with spindle ϕ 3 mm versions with spindle ϕ 4 mm	catalogue number 9904 111 36...				
	104 114	304 314	404 414	504 514	
Nominal voltage	220	110	48	24	V
Current	30	60	140	280	mA
Frequency	50				Hz
Speed	500				rev/min
Input power	6				W
Working torque	33				mNm
Torque derating	-0,4				%/K
Temperature rise of the motor at 50% duty cycle	55				K
Ambient temperature range					
operating	-20 to + 70				$^{\circ}$ C
storage	-40 to + 100				$^{\circ}$ C
Duty cycle	50				%
Permissible voltage fluctuations	-15 to + 10				%
Insulation according to CEE 10	class 1				
Insulation test voltage	1500				V
Bearings	sintered bronze slide				
Maximum radial force	10				N
Maximum axial force	1,5				N
Housing	zinc plated or tinned				
Mass	300				g
Required phasing capacitor C (Fig. 2)	0,22 330	0,82 250	4,7 160	18 63	μ F V

Connections

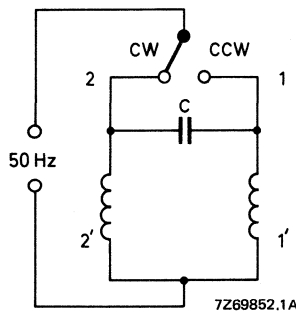

Fig. 2.

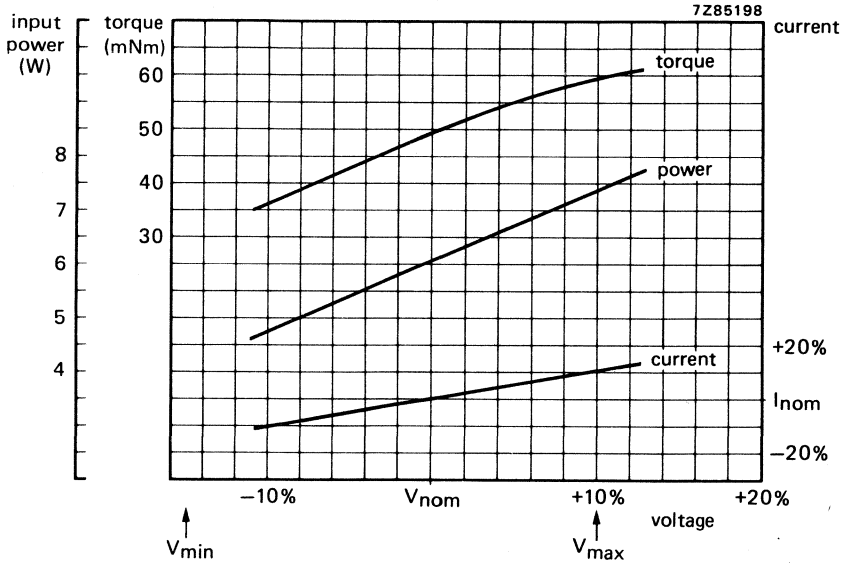

Fig. 3. Typical curves.

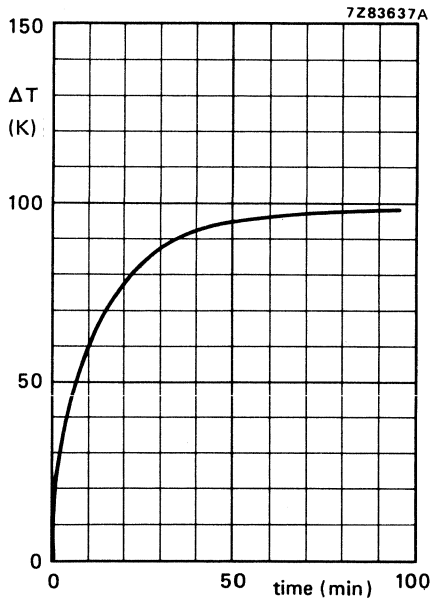

Fig. 4 Temperature increase of the motor versus time of operation.

REVERSIBLE SYNCHRONOUS MOTOR

special purpose

QUICK REFERENCE DATA

Nominal voltage	24 V
Frequency	50 Hz
Speed	500 rev/min
Input power	3,75 W
Torque	20 mNm
Detent torque	18 mNm

APPLICATION

This motor has been designed for those applications which require a detent torque approaching the working torque. This condition is known in industrial controls, valve controls, e.g. in air-conditioning systems.

DESCRIPTION

The motor is specified for parallel-connected coils at 24 V. The design is such that the motor can be used at a 100% duty cycle with a max. temperature rise of 50 K. Thanks to the high detent torque, reversing and stopping can be effected without any unwanted rotation of the spindle.

TECHNICAL DATA

Outlines

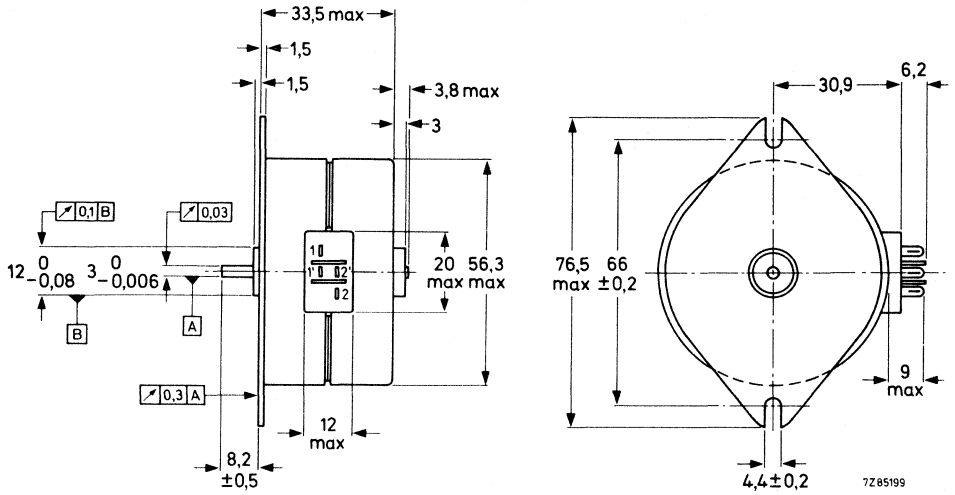

Fig. 1.

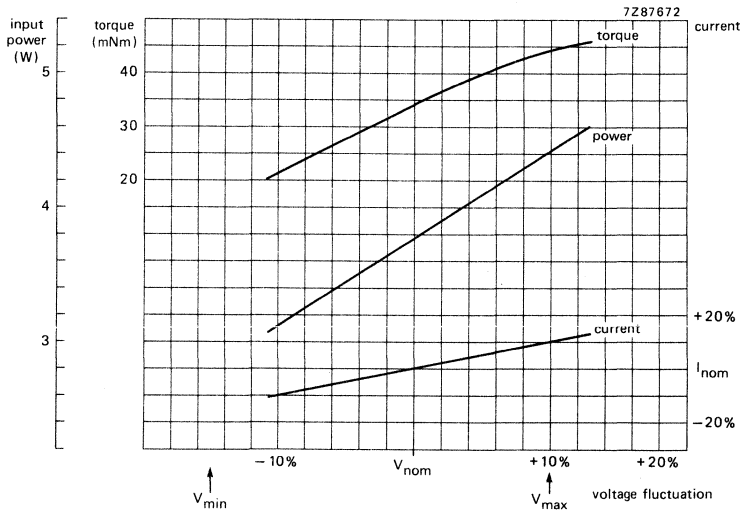

Fig. 2.

	catalogue number 9904 111 36502	
Nominal voltage	24	V
Current	155	mA
Frequency	50	Hz
Speed	500	rev/min
Input power	3,75	W
Working torque	20	mNm
Torque derating	-0,4	%/K
Temperature rise of the motor at 100% duty cycle	50	K
Ambient temperature range		
operating	-20 to + 70	°C
storage	-40 to + 100	°C
Permissible voltage fluctuations	-15 to + 10	%
Insulation according to CEE10	class 1	
Insulation test voltage	1500	V
Bearings	slide	
Maximum radial force	10	N
Maximum axial force	1,5	N
Housing	zinc plated or tinned	
Mass	300	g
Required phasing capacitor C (Fig. 3)	10	μF
	63	V

Connections

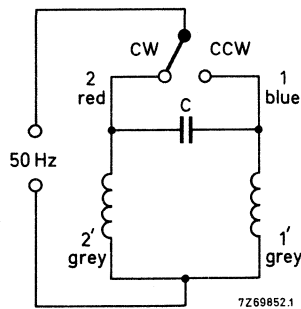

Fig. 3.

LOW-SPEED REVERSIBLE SYNCHRONOUS MOTORS

general purpose

QUICK REFERENCE DATA

Nominal voltage	220/24 V
Frequency	50/60 Hz
Speed	60/72 rev/min
Input power	6 W
Torque	
at 50 Hz	220 mNm
at 60 Hz	180 mNm

APPLICATION

These motors are especially suitable for a.c. servo systems where minimum noise and freedom from maintenance are required.

DESCRIPTION

These motors are the first a.c. synchronous motors based on our hybrid motor principle. They excel in rapid starting, stopping and reversing. The motors combine high torque with low speed. Additional gearing is thereby reduced or even eliminated. A phasing capacitor is used to determine the direction of rotation.

TECHNICAL DATA
Outlines

Dimensions in mm

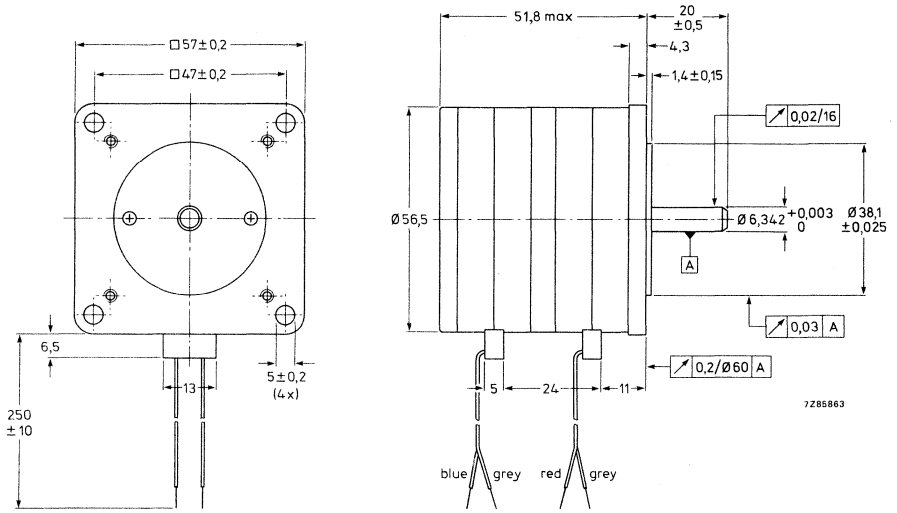

Fig. 1.

The connecting leads are double insulated AWG24, 7-strand.

	catalogue number 9904 116 23 . . 1		
	10	50	
Nominal voltage	220	24	V
Current	27/30	250/270	mA
Frequency	50/60		Hz
Speed	60/72		rev/min
Input power	6		W
Working torque	220/180		mNm
Torque derating	0,4		%/K
Temperature rise of the motor	65		K
Ambient temperature range			
operating	-20 to + 60		°C
storage	-40 to + 100		°C
Permissible voltage fluctuation	-15 to + 10		%
Insulation according to CEE10	class 1		
Insulation test voltage	1500		V
Bearings	ball		
Maximum radial force	50		N
Maximum axial force	20		N
Housing	phosphated sintered iron		
Mass	600		g
Phasing capacitor	0,22/0,18	18/15	μF
Permissible a.c. voltage	330	100	V

Connections

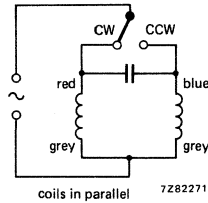

Fig. 2.

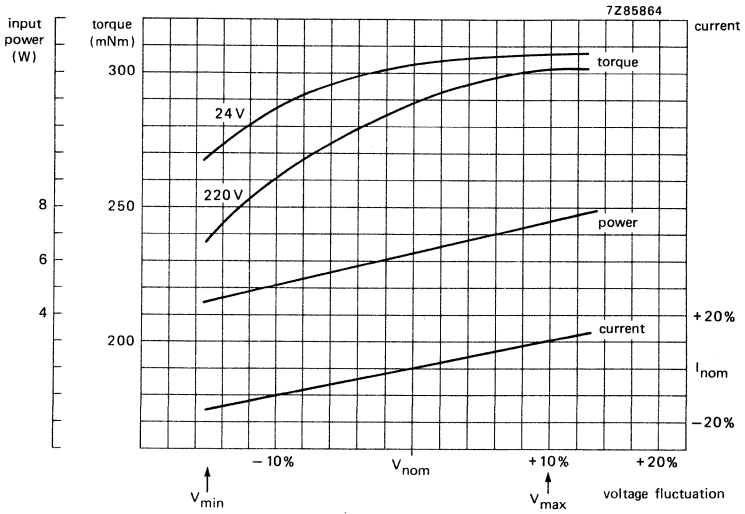

Fig. 3 Typical curves for 50 Hz operation.

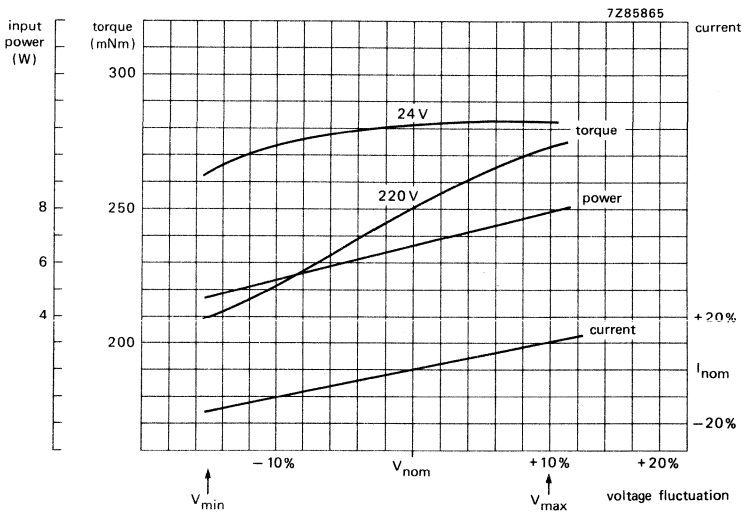
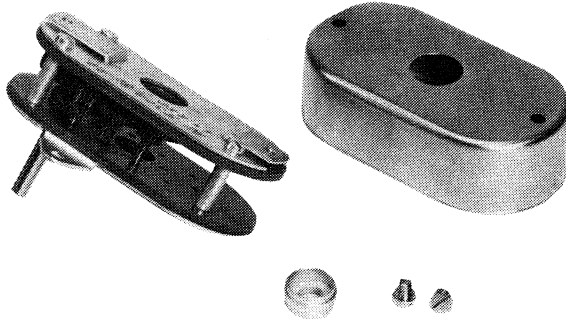

Fig. 4 Typical curves for 60 Hz operation.

GEARBOXES

RZ 12761-6



Series 9904 1301 01. . .

801013-12-02

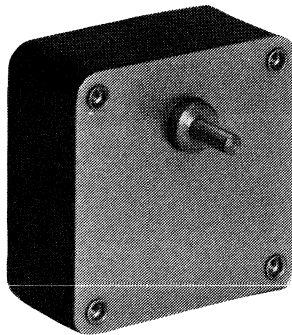

Series 9912 200 0. . .

GEARBOXES

for unidirectional synchronous motors

The reduction gearboxes of the 9904 130 01 . . . series have been designed for use with synchronous motors, fitted with a pinion. They are supplied separately and can easily be mounted to any of these motors.

To attach the motor to the gearbox, place the reversible centring bush in position so that it fits the centring rim on the motor casing, and fasten the motor by means of the two screws in the gearbox cover. For fastening motors 9904 110 05 . . . the gearbox is provided with two threaded holes M2,6. 19 different gear ratios are available in a standard metal casing.

The gearboxes are meant for small series and professional applications with versatility as the main property.

To select an appropriate gearbox, use the survey on the next page.

TECHNICAL DATA

Outlines

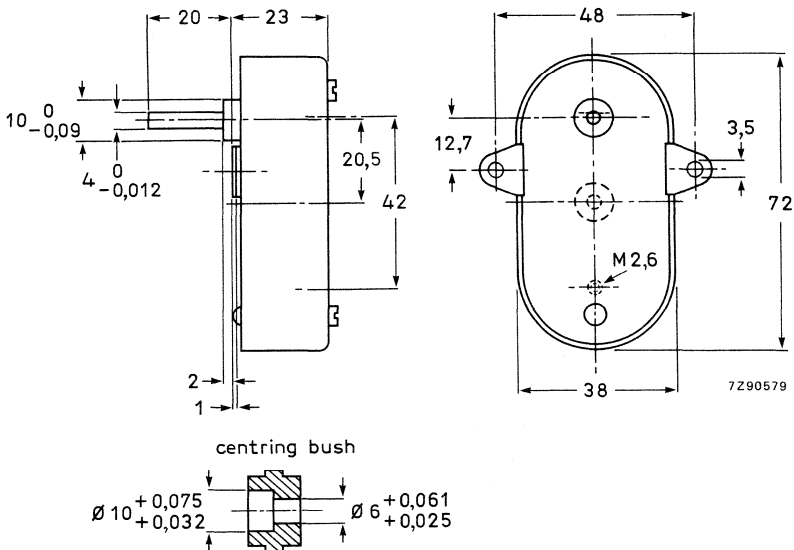

Maximum permissible load	200 mNm
Maximum permissible radial force	10 N
Maximum permissible axial force	2 N

SURVEY

gear ratio	speed of output spindle when coupled to a motor operating from		direction of rotation of output spindle compared to motor spindle*	efficiency	catalogue number
	50 Hz mains	60 Hz mains			
25:6	60 rev/min	72 rev/min	same	0,64	9904 130 01001
25:4	40 rev/min	48 rev/min	same	0,64	01003
25:3	30 rev/min	36 rev/min	same	0,64	01004
10:1	25 rev/min	30 rev/min	same	0,64	01005
25:2	20 rev/min	24 rev/min	same	0,64	01006
50:3	15 rev/min	18 rev/min	opposite	0,51	01008
20:1	12,5 rev/min	15 rev/min	same	0,64	01009
25:1	10 rev/min	12 rev/min	opposite	0,51	01011
100:3	7,5 rev/min	9 rev/min	opposite	0,51	01014
125:3	6 rev/min	7,2 rev/min	opposite	0,51	01016
50:1	5 rev/min	6 rev/min	opposite	0,51	01017
125:2	4 rev/min	4,8 rev/min	opposite	0,51	01019
250:3	3 rev/min	3,6 rev/min	same	0,41	01021
125:1	2 rev/min	2,4 rev/min	opposite	0,51	01023
250:1	1 rev/min	1,2 rev/min	same	0,41	01027
500:1	30 rev/h	36 rev/h	same	0,41	01034
750:1	20 rev/h	24 rev/h	opposite	0,33	01037
1 250:1	12 rev/h	14,4 rev/h	opposite	0,33	01041
15 000:1	1 rev/h	1,2 rev/h	opposite	0,21	01062

* The direction of rotation can, of course, always be adapted by the choice of the motor rotation.

GEARBOXES

for reversible synchronous motors

QUICK REFERENCE DATA

	type G5	type G1	type G15
Reduction ratios	from 25: 6 to 15 000: 1	from 25: 6 to 15 000: 1	from 25: 1 to 5000: 1
Maximum output torque	3 Nm	1 Nm	10 Nm
Locating holes	12 mm	10 mm	12 mm
Maximum radial force	20 N	10 N	30 N
Maximum axial force, push/pull	20 N	10 N	20 N
Maximum power handling	5 W	1,8 W	8 W

DESCRIPTION

Reduction gearboxes of the 9912 200 series are for use with all reverse synchronous motors with 3 mm or 2 mm diameter spindles. They are supplied with two drive pinions, one with a bore of 3 mm, one with a bore of 2 mm. The locating hole in type G1 has a diameter of 10 mm, that in types G5 and G15, 12 mm. A centring bush is supplied with types G5 and G15 to adapt them to motors with a 10 mm diameter centring ridge.

Precision cut, brass gearwheels and bronze bearings pressed into aluminium frames, ensure long, trouble-free life. The frames are shielded from the outside with a sheet of stainless steel. The gearboxes are provided with a dust cover.

TECHNICAL DATA

Outlines

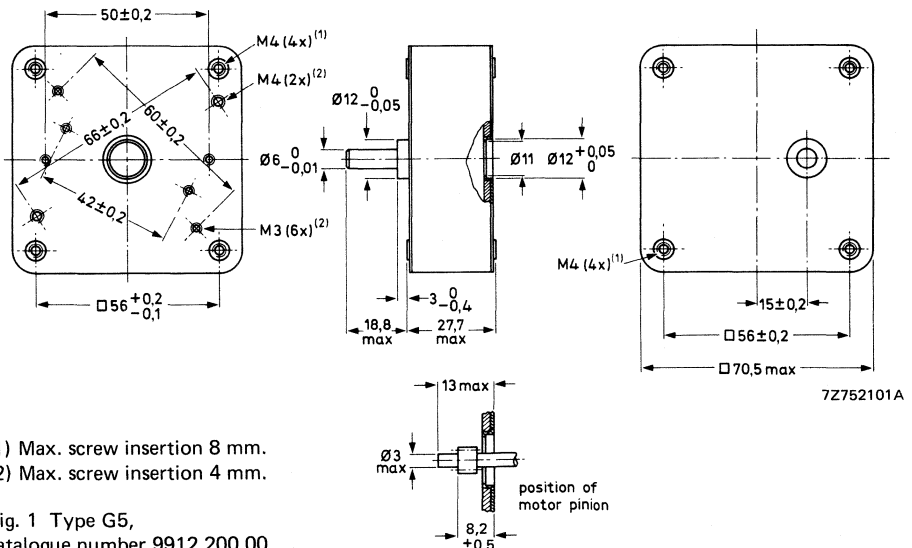

- (1) Max. screw insertion 8 mm.
(2) Max. screw insertion 4 mm.

Fig. 1 Type G5,
catalogue number 9912 200 00. . .

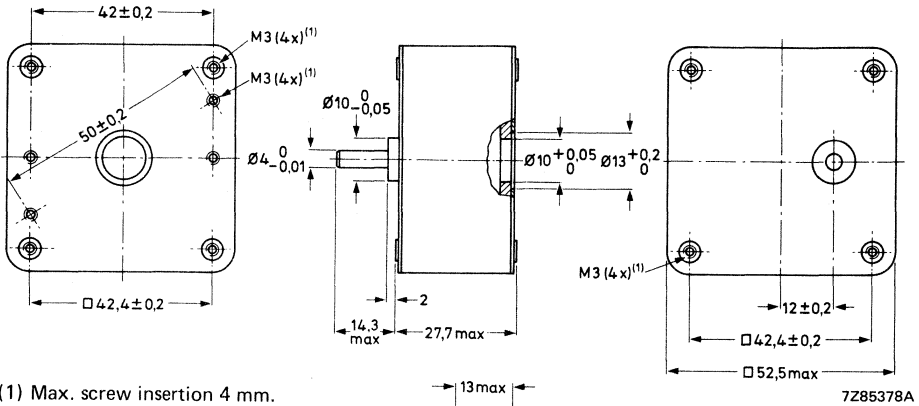

(1) Max. screw insertion 4 mm.

Fig. 2 Type G1,
catalogue number 9912 200 01. . .

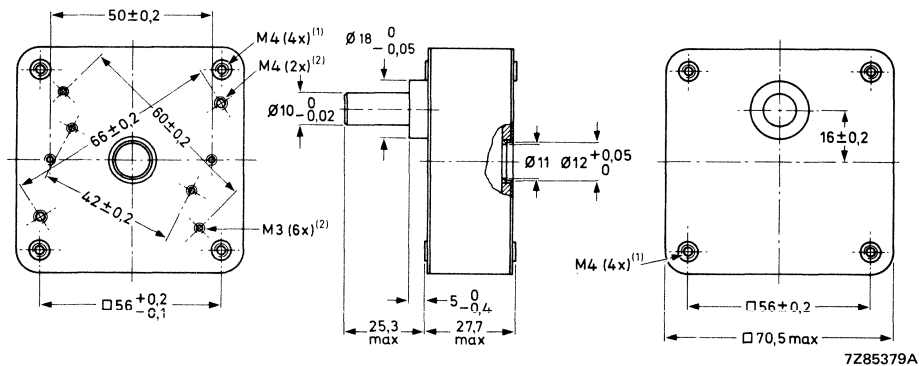

(1) Max. screw insertion 8 mm.

(2) Max. screw insertion 4 mm.

Fig. 3 Type G15,
catalogue number 9912 200 02. . .

Mounting

When pressing the drive pinion onto the motor spindle, support the opposite end of the spindle properly. Protect the pinion teeth during pressing by fitting the brass cap provided.

Motors 9904 111 06... , 9904 111 27... and 9904 111 28... have closed rear covers which must be removed to support the spindle. The spindle of motor 9904 111 06... is not visible when the cover is removed but can be supported via the tapped hole in the bearing bracket. The avoid dislocation of the motor leads, tape them fast while press-fitting the pinion.

Use M3 or M4 screws (see Figs 1, 2 and 3) to attach the motor to the gearbox.

Tapped holes in the corner pillars at the front of the gearboxes facilitate mounting the motor-gearbox assembly.

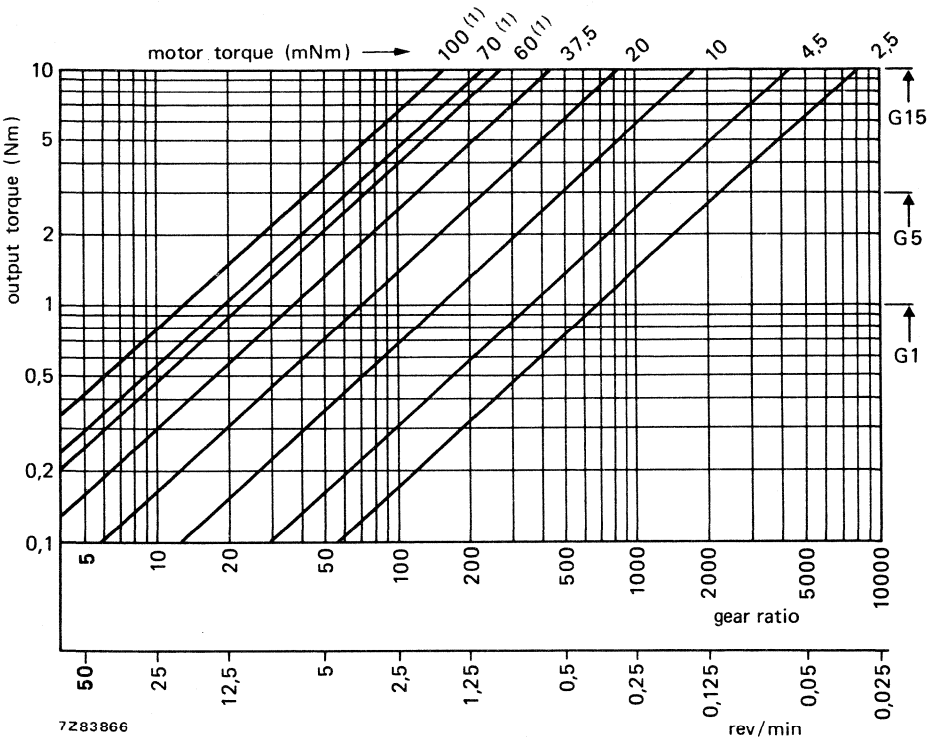

(1) Not applicable to type G1.

Fig. 4 Gearbox output torque as a function of gear ratio at a motor speed of 250 rev/min, with motor torque as parameter. The lower scale shows the corresponding gearbox output speeds.

SURVEY

gear ratio	catalogue number		
	type G5	type G1	type G15
25 : 6	9912 200 00001	9912 200 01001	
25 : 4	9912 200 00003	01003	
25 : 3	00004	9912 200 01004	
10 : 1	00005	01005	
25 : 2	00006	01006	
50 : 3	00008	01008	
20 : 1	00009	01009	
25 : 1	00011	01011	9912 200 02011
100 : 3	00014	01014	
125 : 3	00016	01016	
50 : 1	00017	01017	02017
125 : 2	00019	01019	
250 : 3	00021	01021	
100 : 1			02022
125 : 1	00023	01023	02023
500 : 3		01025	
250 : 1	00027	01027	02027
375 : 1		01031	
500 : 1	00034	01034	02034
625 : 1			02036
750 : 1	00037	01037	
1 000 : 1	00039	01039	
1 250 : 1	00041	01041	
5 000 : 1	00054	01054	02054
15 000 : 1	00062	01062	

List of possible motor/gearbox combinations

Motortype 9904 . . .	Gearboxes 9912 200 . .			Pinions with box:		Remarks
	00 (G5)	01 (G1)	02 (G15)	Ø2	Ø3	
111 32311	★	★	★	★		Use centring bush when combined with: 00 (G5) 02 (G15)
411	★	★	★	★		
511	★	★	★	★		
111 3110 .	★	★	★		★	
30 .	★	★	★		★	
40 .	★	★	★		★	
50 .	★	★	★		★	
111 06101	★	★	★		★	
201	★	★	★		★	
301	★	★	★		★	
401	★	★	★		★	
501	★	★	★		★	
111 27101	★		★		★	
301	★		★		★	
401	★		★		★	
501	★		★		★	
111 28101	★		★		★	
301	★		★		★	
401	★		★		★	
501	★		★		★	
111 33104	★		★		★	
304	★		★		★	
404	★		★		★	
504	★		★		★	
111 34104	★		★		★	
304	★		★		★	
404	★		★		★	
504	★		★		★	
111 35104	★		★		★	
304	★		★		★	
404	★		★		★	
504	★		★		★	
111 36104	★		★		★	
304	★		★		★	
404	★		★		★	
504	★		★		★	

MOUNTING BACKET

for small synchronous motors 9904 110 02...

A special bracket, catalogue number 9904 131 01001 has been made available for mounting the unidirectional motors of the series 9904 110 02. . . to some piece of equipment, which may be a gearbox.

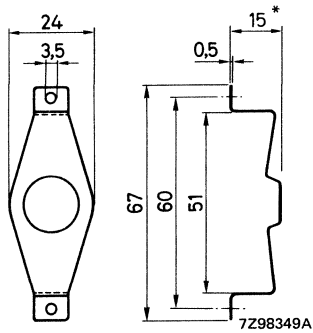

* In mounted position.

INDEX OF CATALOGUE NUMBERS

catalogue no.	page	catalogue no.	page	catalogue no.	page
9904 110 02101	11	9904 111 31101	45	9904 111 33414	61
02111	11	31104	49	33504	61
02301	11	31111	45	33514	61
02311	11	31114	49		
05102	13	31131	45	34104	65
05112	13	31134	49	34114	65
05301	13	31301	45	34304	65
05311	13	31302	41	34314	65
09101	16	31304	49	34404	65
09111	16	31311	45	34414	65
09501	16	31314	49	34504	65
09511	16	31331	45	34514	65
09601	16	31334	49		
09611	16	31401	45	35104	69
09701	16	31404	49	35114	69
09711	16	31411	45	35304	69
		31414	49	35314	69
9904 111 06101	27	31431	45	35404	69
06111	27	31434	49	35414	69
06131	27	31501	45	35504	69
06201	27	31504	49	35414	69
06211	27	31511	45		
06301	27	31514	49	36104	73
06311	27	31531	45	36114	73
06331	27	31534	49	36304	73
06401	27			36314	73
06411	27	32311	53	36404	73
06431	27	32314	57	36414	73
06501	27	32321	53	36502	73
06511	27	32324	57	36504	73
06531	27	32331	53	36514	73
		32334	57		
27101	31	32411	53	9904 116 23101	81
27111	31	32414	57	23501	81
27301	31	32421	53		
27311	31	32424	57	9904 130	87
27401	31	32431	53		
27411	31	32434	57	9904 131 01001	94
27501	31	32511	53		
27511	31	32514	57	9912 200	89
		32521	53		
28101	35	32524	57		
28111	35	32531	53		
28301	35	32534	57		
28401	35				
28411	35	33104	61		
28501	35	33114	61		
28511	35	33304	61		
		33314	61		
30112	39	33404	61		

Argentina: PHILIPS ARGENTINA S.A., Div. Elcoma, Vedia 3892, 1430 BUENOS AIRES, Tel. 541-7141/7242/7343/7444/7545.

Australia: PHILIPS INDUSTRIES HOLDINGS LTD., Elcoma Division, 67 Mars Road, LANE COVE, 2066, N.S.W., Tel. 427 0888.

Austria: ÖSTERREICHISCHE PHILIPS BAUELEMENTE Industrie G.m.b.H., Triester Str. 64, A-1101 WIEN, Tel. 6291 11.

Belgium: N.V. PHILIPS & MBLE ASSOCIATED, 9 rue du Pavillon, B-1030 BRUXELLES, Tel. (02) 242 7400.

Brazil: IBRAPE, Caixa Postal 7383, Av. Brigadeiro Faria Lima, 1735 SAO PAULO, SP, Tel. (011) 2111-2600.

Canada: PHILIPS ELECTRONICS LTD., Electron Devices Div., 601 Milner Ave., SCARBOROUGH, Ontario, M1B 1M8, Tel. 292-5161.

Chile: PHILIPS CHILENA S.A., Av. Santa Maria 0760, SANTIAGO, Tel. 39-4001.

Colombia: SADAPE S.A., P.O. Box 9805, Calle 13, No.51 + 39, BOGOTA D.E. 1., Tel. 600600.

Denmark: MINIWATT A/S, Strandlodsvej 2, P.O. Box 1919, DK 2300 COPENHAGEN S, Tel. (01) 54 11 33.

Finland: OY PHILIPS AB, Elcoma Division, Kaivokatu 8, SF-00100 HELSINKI 10, Tel. 172 71.

France: R.T.C. LA RADIOTECHNIQUE-COMPELEC, 130 Avenue Ledru Rollin, F-75540 PARIS 11, Tel. 355-44-99.

Germany: VALVO, UB Bauelemente der Philips G.m.b.H., Valvo Haus, Burchardstrasse 19, D-2 HAMBURG 1, Tel. (040) 3296-0.

Greece: PHILIPS S.A. HELLENIQUE, Elcoma Division, 52, Av. Syngrou, ATHENS, Tel. 9215111.

Hong Kong: PHILIPS HONG KONG LTD., Elcoma Div., 15/F Philips Ind. Bldg., 24-28 Kung Yip St., KWAI CHUNG, Tel. (0)-24 51 21.

India: PEICO ELECTRONICS & ELECTRICALS LTD., Elcoma Div., Ramon House, 169 Backbay Reclamation, BOMBAY 400020, Tel. 221012.

Indonesia: P.T. PHILIPS-RALIN ELECTRONICS, Elcoma Div., Panim Bank Building, 2nd Fl., Jl. Jend. Sudirman, P.O. Box 223, JAKARTA, Tel. 716 131.

Ireland: PHILIPS ELECTRICAL (IRELAND) LTD., Newstead, Clonskeagh, DUBLIN 14, Tel. 693355.

Italy: Britelec S.R.L., Viale Fulvio Testi 327, I-20162 MILANO, Tel. 02-6445.

Japan: NIHON MICRO MOTOR, Mikamo Bldg., 2-3 chome Sakae-cho, Tachikawa-city, TOKYO, Japan 190, Tel. 0425-27-7722.

Korea: PHILIPS ELECTRONICS (KOREA) LTD., Elcoma Div., Philips House, 260-199 Itaewon-dong, Yongsan-ku, C.P.O. Box 3680, SEOUL, Tel. 794-4202.

Malaysia: PHILIPS MALAYSIA SDN. BERHAD, No. 4 Persiaran Barat, Petaling Jaya, P.O.B. 2163, KUALA LUMPUR, Selangor, Tel. 77 44 11.

Mexico: ELECTRONICA, S.A de C.V., Carr. Mexico-Toluca km. 62.5, TOLUCA, Edo. de Mexico 50140, Tel. Toluca 91(721) 613-00.

Netherlands: PHILIPS NEDERLAND, Marktgroep Elcon, Postbus 90050, 5600 PB EINDHOVEN, Tel. (040) 79 33 33.

New Zealand: PHILIPS ELECTRICAL IND. LTD., Elcoma Division, 110 Mt. Eden Road, C.P.O. Box 1041, AUCKLAND, Tel. 605-914.

Norway: NORSK A/S PHILIPS, Electronica Dept., Sandstuveien 70, OSLO 6, Tel. 68 02 00.

Peru: CADESA, Av. Jiron Nazca 704, Apartado No. 5612, LIMA II, Peru, Tel. 319253.

Philippines: PHILIPS INDUSTRIAL DEV. INC., 2246 Pasong Tamo, P.O. Box 911, Makati Comm. Centre, MAKATI-RIZAL 3116, Tel. 86-89-51 to 59.

Portugal: PHILIPS PORTUGESA S.A.R.L., Av. Eng. Duarte Pacheco 6, 1009 LISBOA Codex, Tel. 68 31 21.

Singapore: PHILIPS PROJECT DEV. (Singapore) PTE LTD., Elcoma Div., Lorong 1, Toa Payoh, SINGAPORE 1231, Tel. 25 38 811.

South Africa: EDAC (Pty.) Ltd., 3rd Floor Rainer House, Upper Railway Rd. & Ove St., New Doornfontein, JOHANNESBURG 2001, Tel. 614-2362/9.

Spain: MINIWATT S.A., Balmes 22, BARCELONA 7, Tel. 301 63 12.

Sweden: PHILIPS KOMPLEMENTER A.B., Lidingövägen 50, S-11584 STOCKHOLM 27, Tel. 08/7821000.

Switzerland: PHILIPS A.G., Elcoma Dept., Allmendstrasse 140-142, CH-8027 ZÜRICH, Tel. 01-48822 11.

Taiwan: PHILIPS TAIWAN LTD., 3rd Fl., San Min Building, 57-1, Chung Shan N. Rd, Section 2, P.O. Box 22978, TAIPEI, Tel. (02)-5631717.

Thailand: PHILIPS ELECTRICAL CO. OF THAILAND LTD., 283 Silom Road, P.O. Box 961, BANGKOK, Tel. 233-6330-9.

Turkey: TURK PHILIPS TICARET A.S., EMET Department, Inonu Cad. No. 78-80, ISTANBUL, Tel. 4359 10.

United Kingdom: Impex Electrical Ltd., Market Road, Richmond, SURREY, Tel. 01-8761047.

United States: North American Philips Controls Corp., Cheshire Industrial Park, Cheshire, Conn. 06410, Tel. (203) 272-0301.

Uruguay: LUZIELECTRON S.A., Avda Uruguay 1287, P.O. Box 907, MONTEVIDEO, Tel. 91 43 21.

Venezuela: IND. VENEZOLANAS PHILIPS S.A., Elcoma Dept., A. Ppal de los Ruices, Edif. Centro Colgate, CARACAS, Tel. 3605 11.